

## Pisko® SafeLine wire end protector installation

When crimping the SafeLine wire end protector, use a crimping machine with a minimum of 53 kN crimping force. Use hexagonal dies. For example, Milwaukee M18 HCCT-201C crimping machine equipped with R22 CU 35 crimping jaw pack. When crimping stainless steel terminals, replacement interval for the jaws may be more frequent than usual.

Approved implementation of the wire end protector is always verified with a crimp connection gauge. The verification is performed on the first and last crimp of the wire end protector, in accordance with the instructions on the next page. Inspections of the crimping on extensions and wire end protectors are recorded on the SafeLine system's commissioning and annual inspection form.

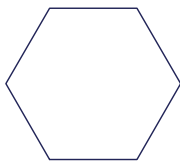

Hexagonal crimp profile of the jaws when fully closed.

### CRIMPING THE WIRE END PROTECTOR ONTO THE WIRE

Insert the wire end protector on the wire.  
Check through the side opening of the wire end protector that the end of the wire reaches the bottom of the cavity in the end protector.

Make the crimps between the marking lines on the wire end protector. Make 3 crimps.

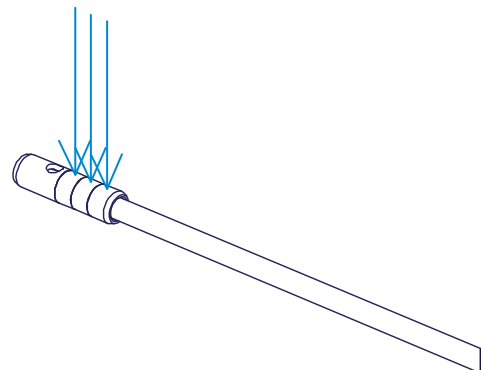
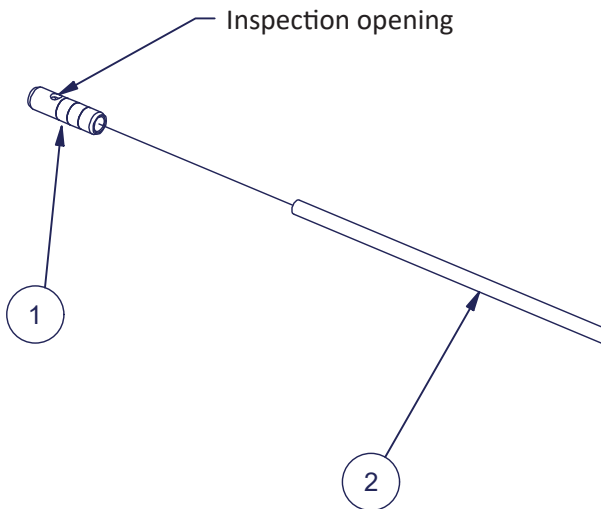

Part	Description
1	Wire end protector (957)
2	Pisko SafeLine stainless steel wire, 8 mm (965, 966)

## CRIMP CONNECTION GAUGE

Crimp connection gauges are always supplied in pairs. Before verifying the crimping of the extension, the dimensional accuracy of the gauge being used must be verified with the other gauge.

The gauge verification is performed by placing the bridge in the middle of the second gauge into the crimp-inspection slot of the gauge being checked. The bridge is inserted into the slot using its narrower section, and from this position, the gauge under inspection is then attempted to be slid into the wider section of the bridge. The gauge is dimensionally accurate and acceptable if it does not fit into the wider section.

The gauges are engraved with their year and month of manufacture. The gauges must be replaced with new ones every 2 years.

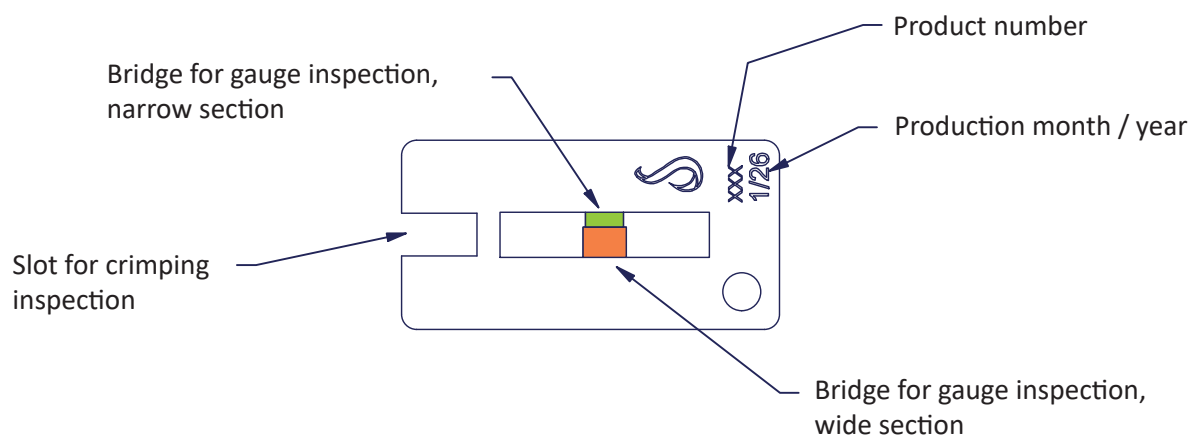

### Gauge accuracy verification

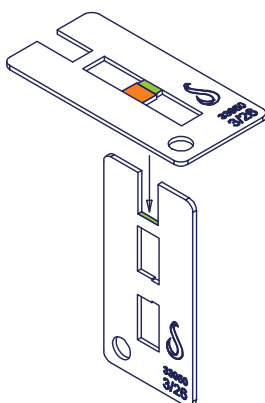

Insert the narrow section of the gauge's bridge into the crimping inspection slot of the gauge being inspected.

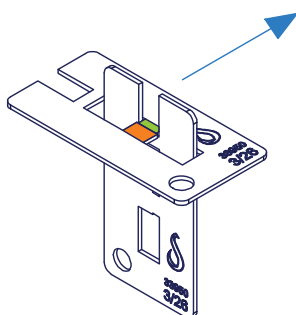

Slide the gauge being inspected in the slot toward the wider section of the bridge.

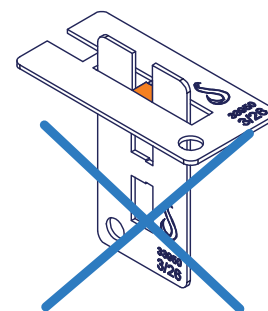

If the gauge fits into the wider section of the bridge, the gauge is no longer dimensionally accurate and cannot be used for approved crimping inspections.

The crimping machine produces a hexagonal Crimp. The crimp connection gauge is used to verify that the crimp has compressed the wire end protector sufficiently to achieve the required holding force on the wire. The verification is performed by placing the crimping inspection slot on the gauge over the crimping surfaces of the crimp being inspected. Due to the jaw geometry of the crimping machine, the distance between two of the crimping surface pairs is smaller than the distance of the third crimping surfaces. The gauge is used to check the two smallest surface pairs. The third, largest gap does not need to be checked.

For the crimp to be accepted, the crimping surfaces must fit entirely within the slot of the gauge. There must be two pairs of crimping surfaces – within the same single crimp - over which the gauge fits completely.

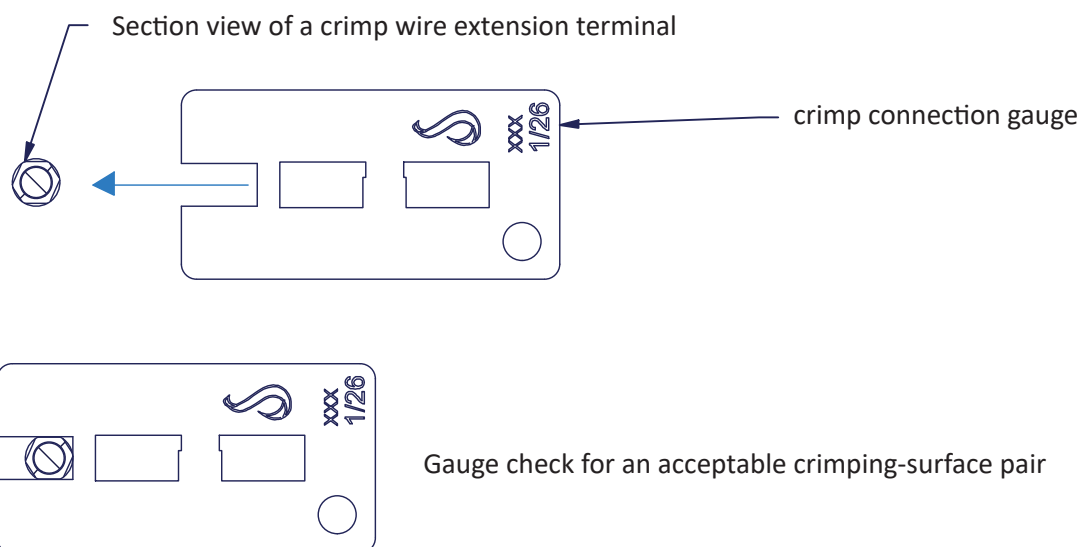

For each wire end protector, the first and the last crimp are inspected. For each crimp, two pairs of the crimping surfaces are checked. If the gauge does not fit over two of the three crimping-surface pairs in any of the inspected crimps, the crimp is rejected and must be redone. When two acceptable surface pairs are found on the same crimp, the third surface pair does not need to be checked, and the gauge may not even fit over the third surface pair.

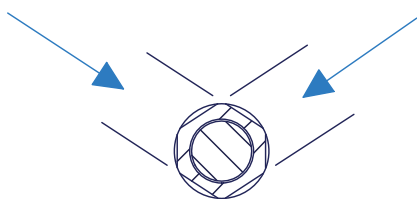

Verification of two crimping surfaces with the gauge.

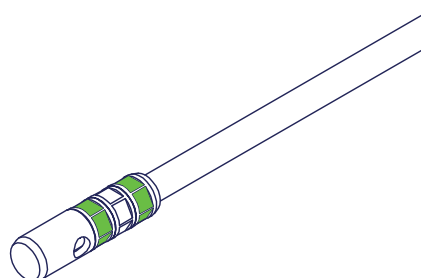

The crimps to be inspected on the wire end protector shown with color highlight.

## INSPECTION OF THE CRIMPING SURFACES ON THE WIRE END PROTECTOR

The orientation of the surfaces to be checked does not necessarily correspond to the orientations shown in the illustrations, as they depend on the position of the crimping machine around the circumference of the wire end protector.

The illustrations show the verification of the surface pairs on the first crimp. In addition, the other crimps highlighted in color on the previous page must also be inspected.

When performing the inspection, care must be taken not to inspect the same side twice by moving the gauge to the opposite side of the crimping surfaces that have already been checked.

### Inspection of the first crimp's first crimping-surface pair

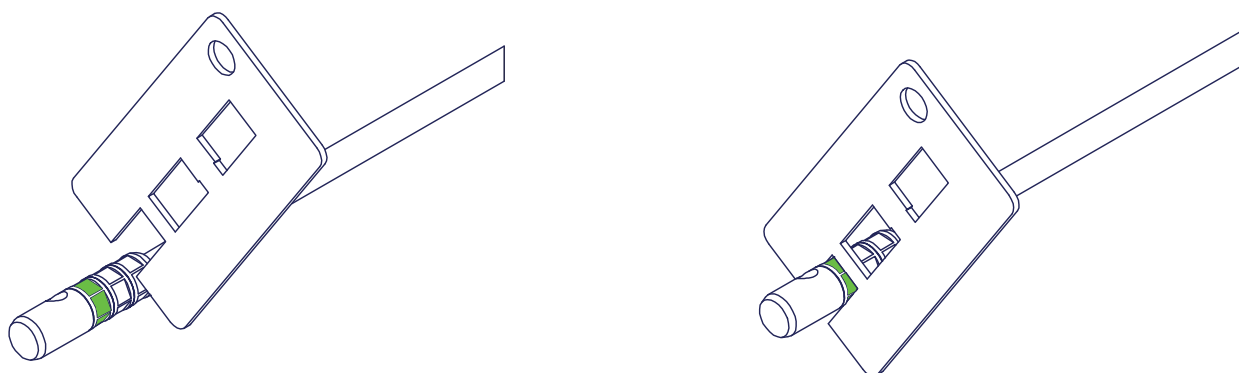

### Inspection of the first crimp's second crimping-surface pair

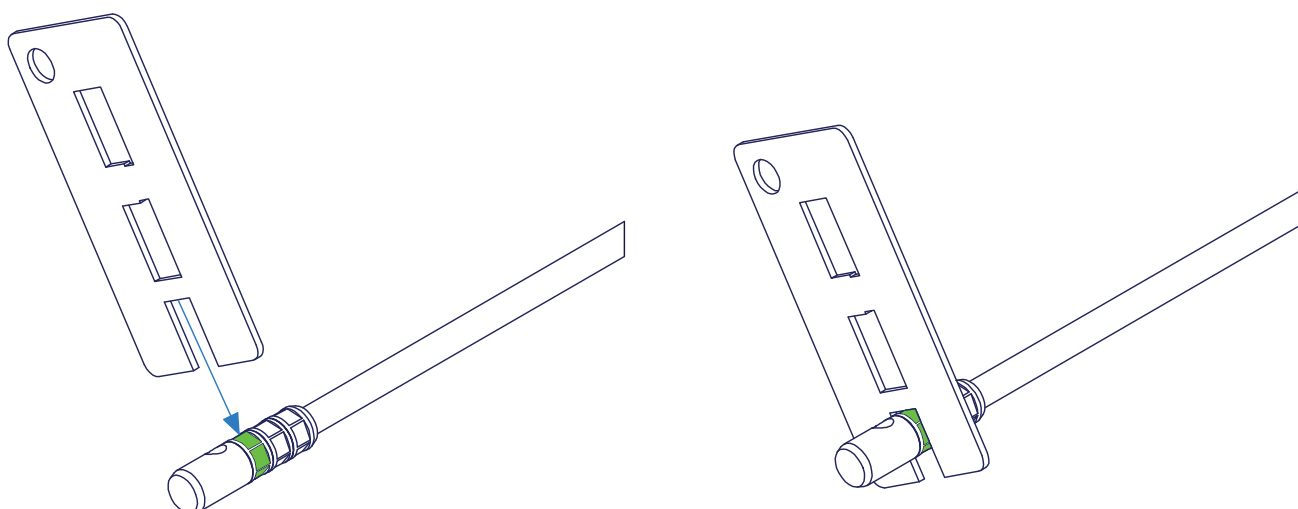

## INSTALLATION INSTRUCTIONS REVISION HISTORY

Installation instruction - Pisko Safeline wire end protector installation

Version	Date	Notable changes
1.1	24.6.2026	New Installation Instructions. Revision history of the installation instructions is included in the installation instructions