

Pisko snow guard for profiled sheets, up to 45 mm of height

The snow guard must be positioned as close to the eaves as possible so that the load of the snow is directed towards load-bearing structures. Secure the snow guard pipes in place by pipe fixing screws through the pipes, next to the outmost brackets (figures 2,6).

The distance between the adjacent roof brackets shall not be more than 1000 mm, when using the installation method on top of the load bearing sheet. When the roof bracket is fixed to the under structure (battens) the distance between the brackets may be up to 1100 mm. The edges of the snow guard pipes shall not outreach the closest roof bracket by more than 200 mm. (figures 1,5)

For load bearing profiles there are two installation methods. However, the recommended method for low profiles ($h \leq 45$ mm) is to fix the brackets to the under structures. If the profile has not been designed and executed as a load bearing steel structure, fixing the bracket to the under structures is the **only** allowed installation method.

FIXING THE BRACKET TO THE BOTTOM OF THE PROFILED SHEET

When the profiled sheet acts as a non-load bearing roof, or it is impossible to tell whether the structure has been executed as a load bearing structure, the brackets (for example LE SK 400) shall be installed on top of the battens, by fixing the bracket with three 7x40 mm HVAC screws. Before installing the brackets, make sure that the c/c parting of the battens is suitable for the bracket. Screws must properly hit the battens in order to create enough pull-out strength. The battens should be min. 32 mm thick, good quality structural wood. Use two screws on the top part of the bracket, and one on the eaves side (figure 4).

Ensure the water tightness by using a suitable rubber sealant between the bracket and the profiled sheet (figure 3).

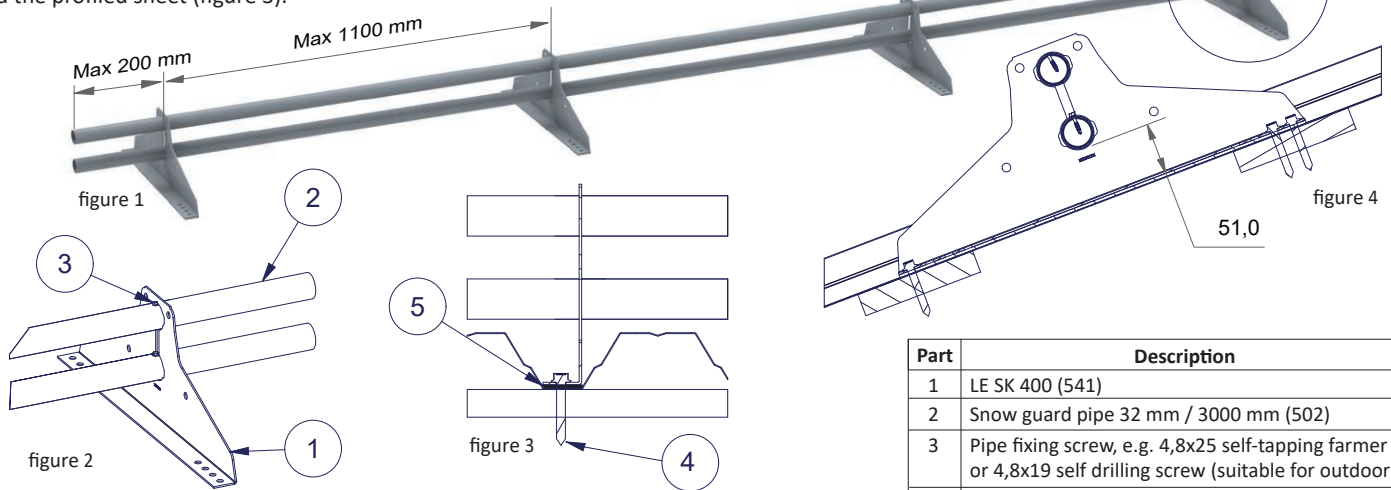

Part	Description
1	LE SK 400 (541)
2	Snow guard pipe 32 mm / 3000 mm (502)
3	Pipe fixing screw, e.g. 4,8x25 self-tapping farmer screw or 4,8x19 self drilling screw (suitable for outdoor use)
4	HVAC screw 7x40 mm (664) (suitable for outdoor use)
5	EPDM sealant strip (580) / Pisko 2+1 seal (582)

FIXING THE BRACKET TO THE CROWN OF THE LOAD BEARING SHEET

The requirement to use this option is, that the sheet has been designed and executed as a load bearing steel structure, and the minimum thickness of the material is 0,6 mm.

The LE 350 on top of profile brackets shall be installed directly to the crown of the profile. Fix the bracket to the sheet by using four Pisko sheet metal screws or 7x40 HVAC screws, on the bended side edge of the bracket (figures 6, 7).

Ensure the water tightness by using a Pisko 2+1 seals (6) or, for example, EPDM sealant strip between the bracket and the profiled sheet (figure 7).

When the snow guard is fixed to a load bearing sheet, it is recommended to use separate extra bracket for profile bottom, that are to be designed according to the height of the load bearing sheet's crown. Extra bracket for profile bottom prevents the ice and snow from sliding under the snow barrier pipes.

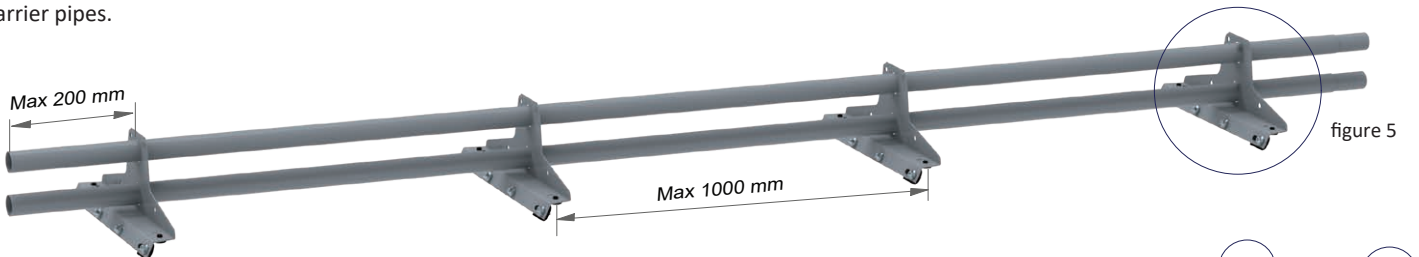

Part	Description
1	LE 350 on top of profile (545)
2	Pisko sheet metal screw (669) or HVAC screw 7x40 mm (664)
3	Snow guard pipe 32 mm / 3000 mm (502)
4	Pipe fixing screw, e.g. 4,8x25 self-tapping farmer screw or 4,8x19 self drilling screw (suitable for outdoor use)
5	Pisko 2+1 seal (582) / EPDM sealant strip (580)

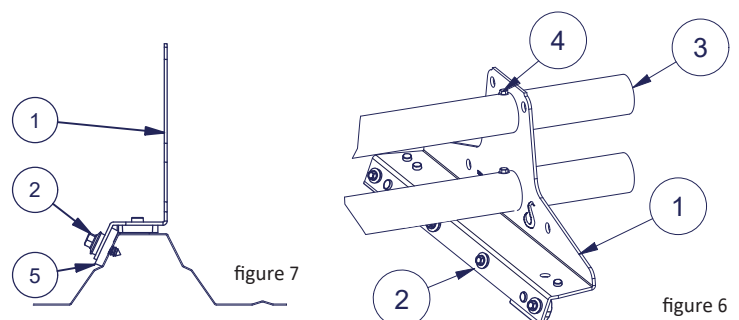

MAXIMUM LENGTH OF ROOF SLOPE (RT Reference Card 85-11132)

Indicative figures for the maximum distance (m) of the roof slope above the snow guard on a smooth surface. The maximum distance on coarse roofs, such as bitumen roofs can be increased by 1.3 – 1.5 times the stated amount. The snow load values shown are the actual snow loads on a roof.

Roof's inclination angle (°) and snow ratio (the ratio of the slope to the horizontal width of the roof pane)	Maximum length of slope above the snow guards					
The characteristic value of the snow load on the roof: 1,8 kN/m ²						
Space between the snow guard fasteners	0,5 m	0,6 m	0,75 m	0,9 m	1,0 m	1,2 m
Roof's inclination angle and snow ratio						
< 15°, (1:3,7)	21,4	17,9	14,3	12,0	10,7	9,0
15... 22°, 1:3,7... 1:2,5	11,4	9,5	7,6	6,3	5,7	4,8
22... 27°, 1:2,5... 1:2	8,4	7,0	5,6	4,7	4,2	3,5
27... 37°, 1:2... 1:1,3	7,4	6,2	4,9	4,1	3,7	3,1
37... 45°, 1:1,3... 1:1	9,0	7,5	5,9	5,0	4,5	3,7
The characteristic value of the snow load on the roof: 2,0 kN/m ²						
Space between the snow guard fasteners	0,5 m	0,6 m	0,75 m	0,9 m	1,0 m	1,2 m
Roof's inclination angle and snow ratio						
< 15°, (1:3,7)	19,1	16,1	12,9	10,8	9,6	8,1
15... 22°, 1:3,7... 1:2,5	10,2	8,6	6,9	5,7	5,1	4,3
22... 27°, 1:2,5... 1:2	7,6	6,3	5,1	4,2	3,8	3,2
27... 37°, 1:2... 1:1,3	6,7	5,6	4,4	3,7	3,3	2,8
37... 45°, 1:1,3... 1:1	8,2	6,8	5,3	4,5	4,1	3,3
The characteristic value of the snow load on the roof: 2,6 kN/m ²						
Space between the snow guard fasteners	0,5 m	0,6 m	0,75 m	0,9 m	1,0 m	1,2 m
Roof's inclination angle and snow ratio						
< 15°, (1:3,7)	15,0	12,5	9,9	8,3	7,5	6,2
15... 22°, 1:3,7... 1:2,5	8,0	6,6	5,3	4,4	4,0	3,3
22... 27°, 1:2,5... 1:2	5,8	4,8	3,9	3,3	2,9	2,4
27... 37°, 1:2... 1:1,3	5,2	4,3	3,4	2,8	2,6	2,1
37... 45°, 1:1,3... 1:1	6,2	5,2	4,1	3,5	3,1	2,6

PICTURED IS AN EXAMPLE OF SNOW GUARDS BEING USED ACCORDING TO THE TABLE.

Maximum length of the slope above the snow guards: 4,7 m

Roof angle 25°
Snow load 1,8 kN/m²

Space between the snow guard fasteners: 900 mm



Maximum length of the slope above the snow guards: 3,3 m

Roof angle 25°
Snow load 2,6 kN/m²

Space between the snow guard fasteners: 900 mm



Pisko Snow Guards are capable of bearing a load of at least 5 kN/m, in the direction of the inclined roof. By following the values in the table these requirements are fulfilled.

<p>EUF129-19002814-VA</p>	<p>Piristeel Oy Metallitie 4 FI-62200 Kauhava</p>
	<p>Product: Pisko snow guards</p> <p>Intended Purpose: A roof safety product – The snow guards are used for preventing snow and ice falling from the roof.</p> <p>Performance levels:</p> <p>1. Minimum height: Declared</p> <p>2. Extensions: Fixed</p> <p>3. Static load-bearing capacity: With a 1.5-kN concentrated load and a 5-kN load in the inclination direction of the pitched roof area, the deflection is less than 20 mm and the permanent deflection less than 5 mm.</p> <p>4. Corrosion resistance: Corrosion resistance class C3 medium</p>

MAINTENANCE

Pisko products are hard-wearing and safe to use, guaranteed by the ongoing quality control and development work by Piristeel Ltd, as well as correct installation of the products according to the manufacturer's instructions. To ensure the reliability and safety of the products, the property owner must carry out yearly inspection and maintenance procedures, and monitor that the snow load specified by the regulations is not exceeded.

- Check the tightness of joints, connections and attachments.
- Ensure any excessive snow load is cleared to minimize the strain on structures and attachment points (as necessary; there might be a need several times during the winter). Product durability in accordance with the certification certificate.
- Check the paintwork and zinc coating of the products; repair faults and touch up paintwork if necessary
- Replace or repair any damaged or faulty parts as soon as possible.