

Pisko® Safeguard guardrail system installation to roof ladder

Pisko Safeguard is a system that prevents access to hazardous areas and can also be used as an attachment point for safety ropes. Before starting installation work, ensure that the access ways used as the installation base comply with class 2 performance requirements (suitable for attaching safety ropes). The railing must always be secured with at least three fasteners/posts. The Safeguard guardrail system can be installed at a maximum angle of 45° in the direction of the access way.

INSTALLATION

Place the Safeguard bottom bracket on the underside of the roof ladder as shown in figure 2. The bottom brackets should be installed as close below the rung as possible, so that walking on the roof ladder is not made difficult especially on steeper roofs. Tighten the M8x40 flange screws to a torque of 10 Nm.

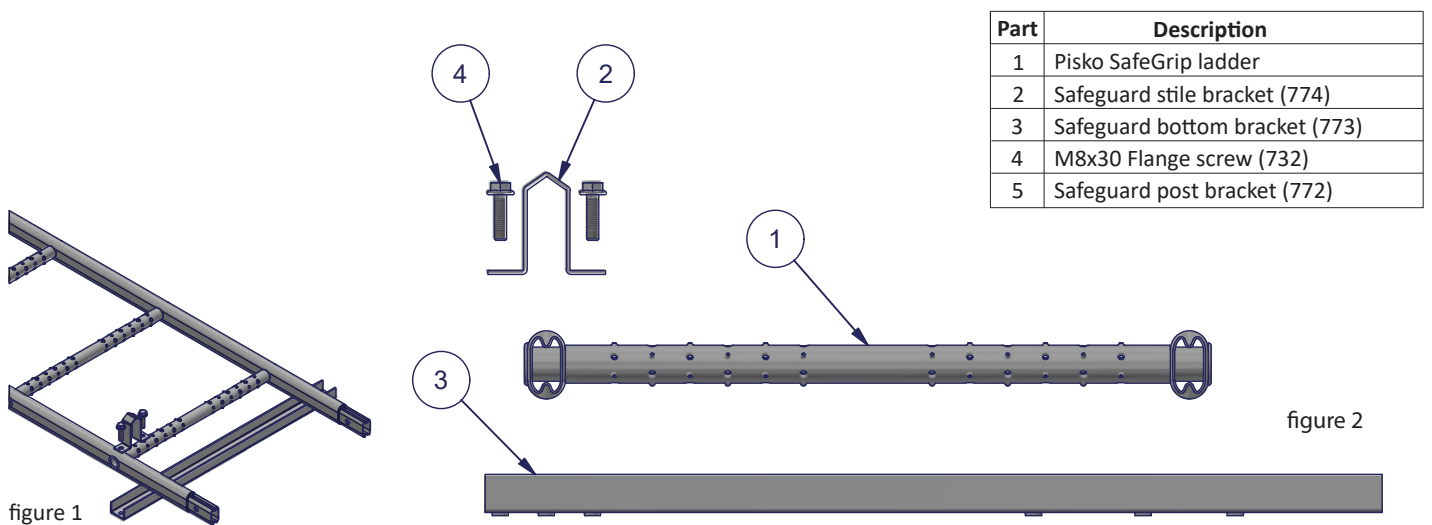

Place the post bracket between the bottom bracket and the roof ladder. Tighten the M8x30 flange screws to a torque of 10 Nm (figure 4).

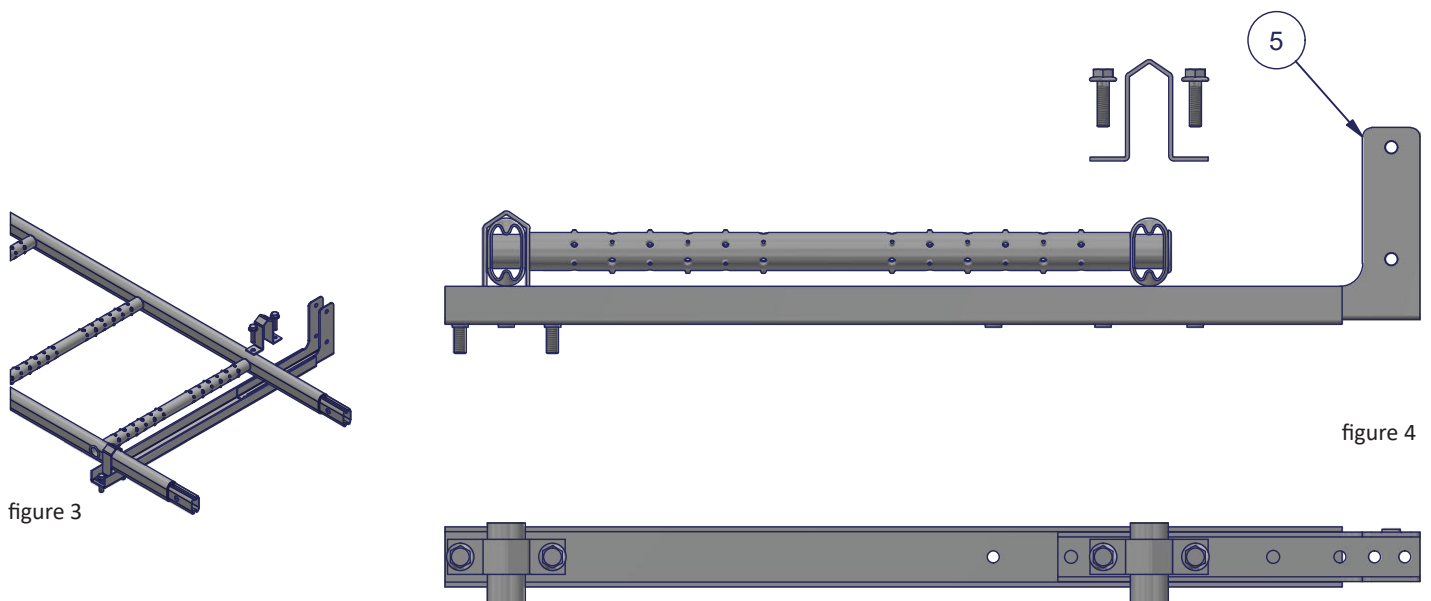

Place the post in the post bracket and tighten the two M8x40 flange screws to a torque of 10 Nm (figure 5).

The marking notch at the other end of the post should face downwards! This will ensure that the handrails are set at the correct height.

Place the handrail brackets on the side of the post as shown in the figure, with threaded collars on the outside. Insert the M8x40 flange screws into the lower holes. Do not tighten the screws completely. Handrail bracket bottom will remain against the post, making it easy to drop the handrails into place from above.

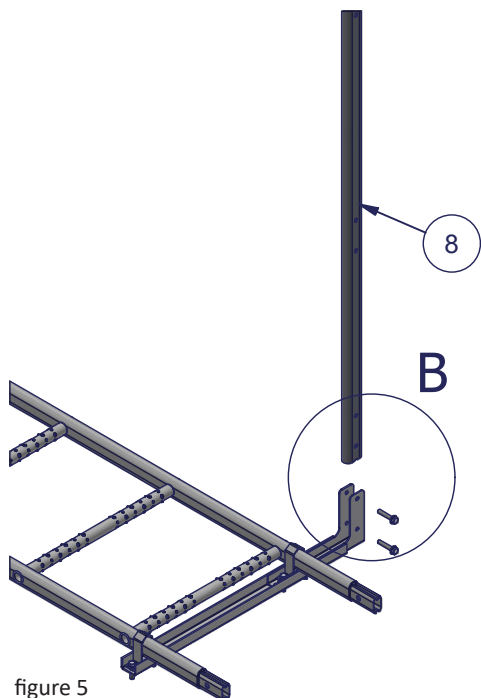

figure 5

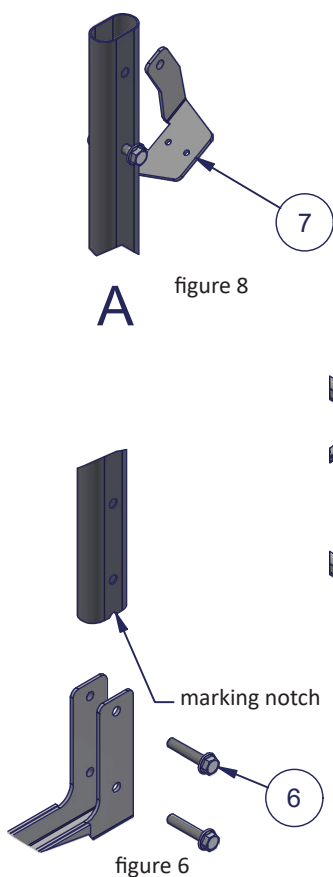

figure 8

figure 6

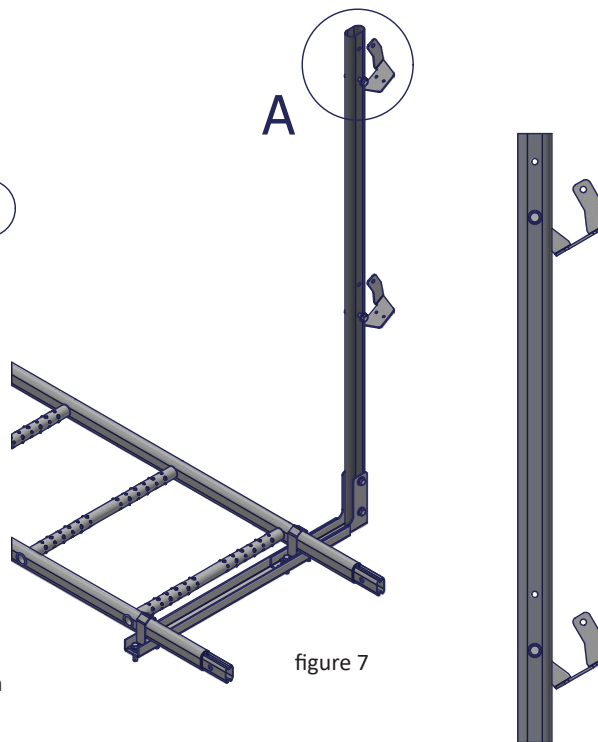

figure 7

figure 9

Part	Description
6	M8x40 flange screw (733)
7	Safeguard handrail bracket (771)
8	Safeguard post (770)

Brackets, posts and handrail brackets can be installed at this stage. The maximum distance between the posts is 1500 mm.

Install at least two posts with brackets at a time, this makes it easier to install the handrails.

The railing can also be installed on both sides of the access way. In this case, twice the number of Safeguard system components will be required.

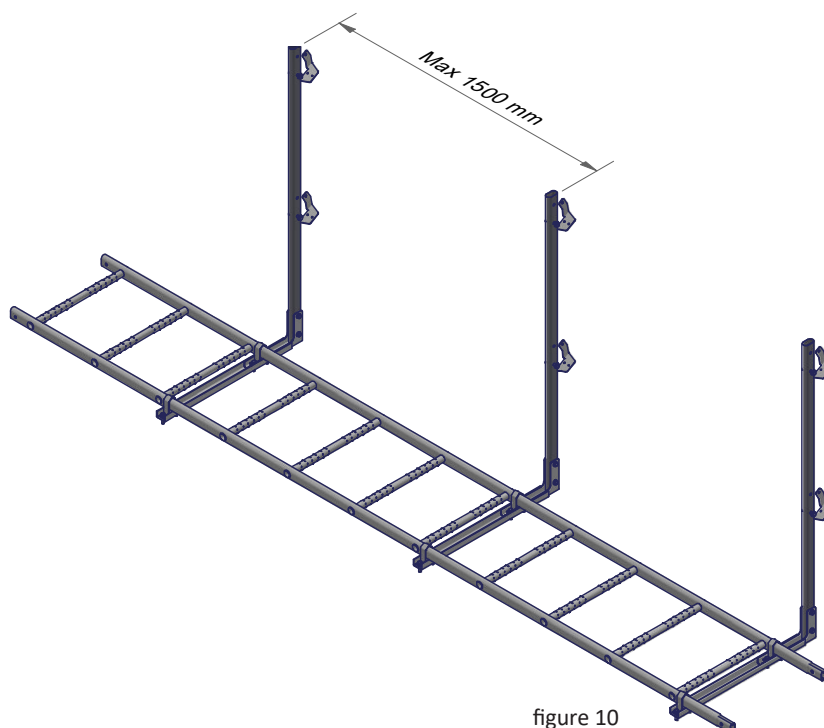

figure 10

Place the first handrails (Pisko snow guards) to handrail brackets as hown in figure 12.

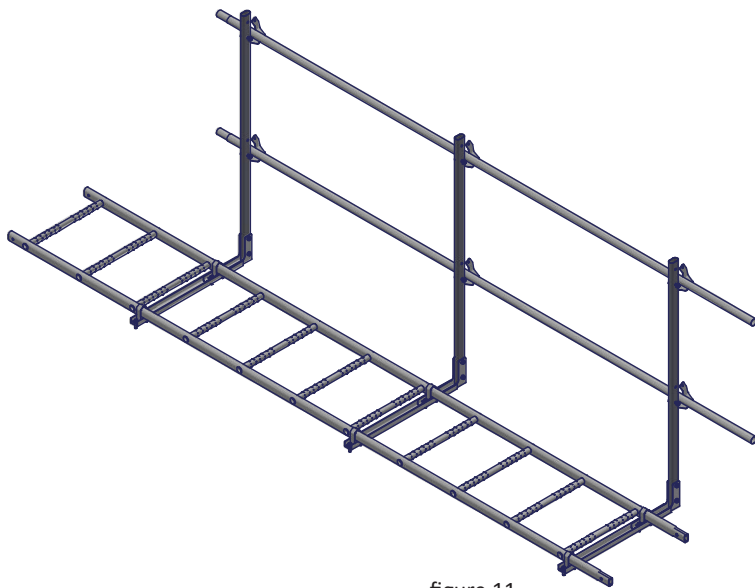

figure 11

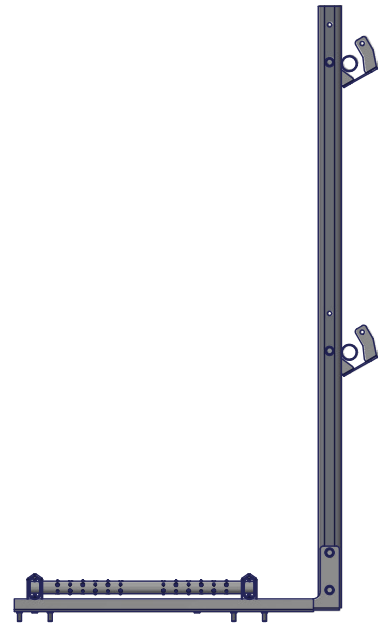

figure 12

Turn the handrail brackets upright and insert the M8x40 flange screws into the upper holes of the post. Tighten both upper and lower screws to a torque of 10 Nm.

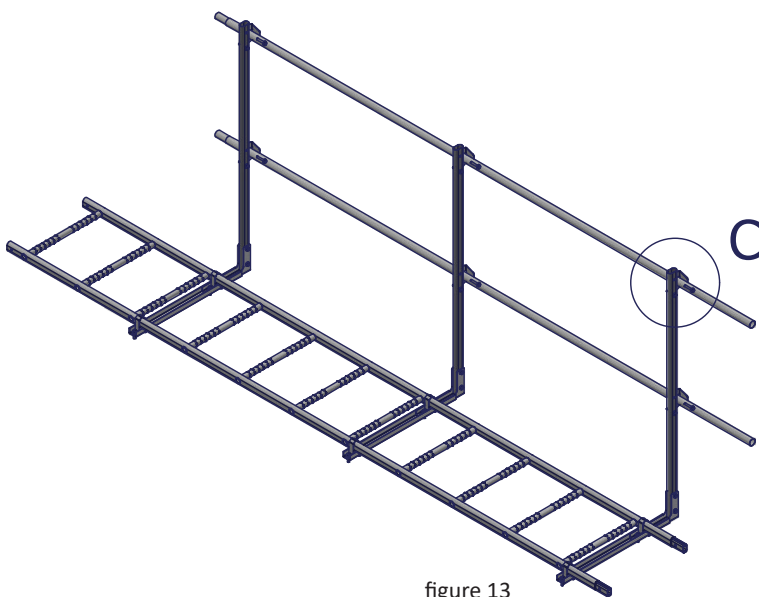

figure 13

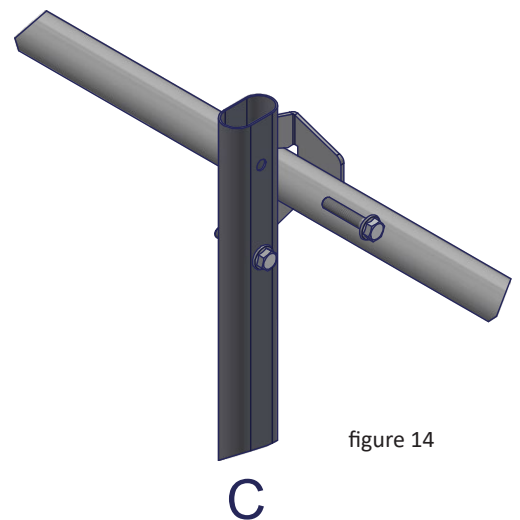

figure 14

Secure the handrails to the handrail brackets using 4,8 x 19 mm drill vap screws. The handrail must extend beyond the outermost post by at least 100 mm and at most 400 mm.

Two drill vap screws per bracket are installed in the handrail brackets of the first and the last post (figure 17). One drill vap screw is installed in the upper handrail bracket of the posts between the first and the last post (figure 16).

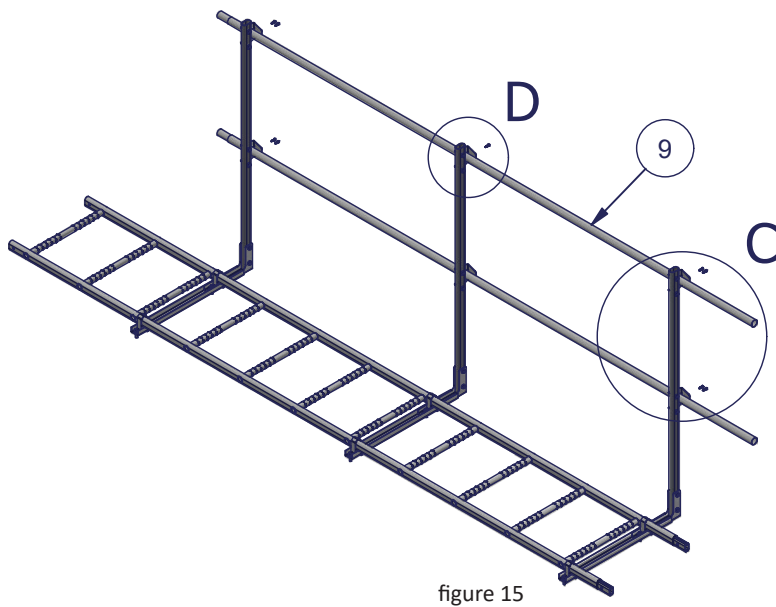

figure 15

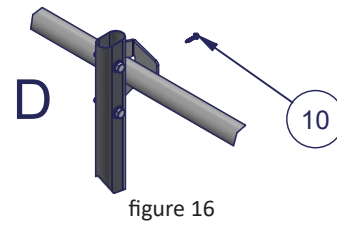

figure 16

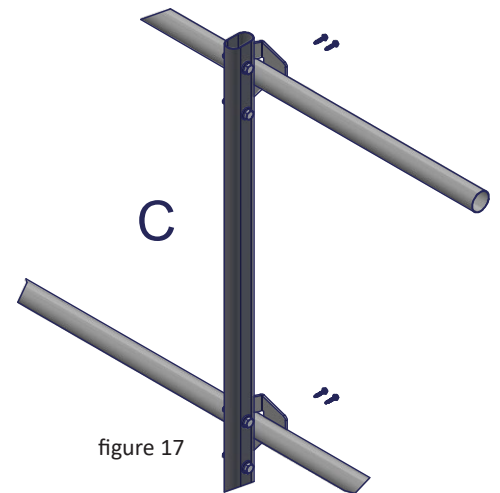

figure 17

Part	Description
9	Handrail (Pisko snow guard pipe 502)
10	Drill vap screw 4,8 x 19 mm (594)

Place the next handrails in the open handrail brackets. Lift the handrail brackets upright and tighten the M8x40 flange screws to a torque of 10 Nm.

Push the crimped end of the handrail pipe into the non-crimped pipe.

Lock each joint with two 4,8 x 19 mm drill vap screws.



figure 18

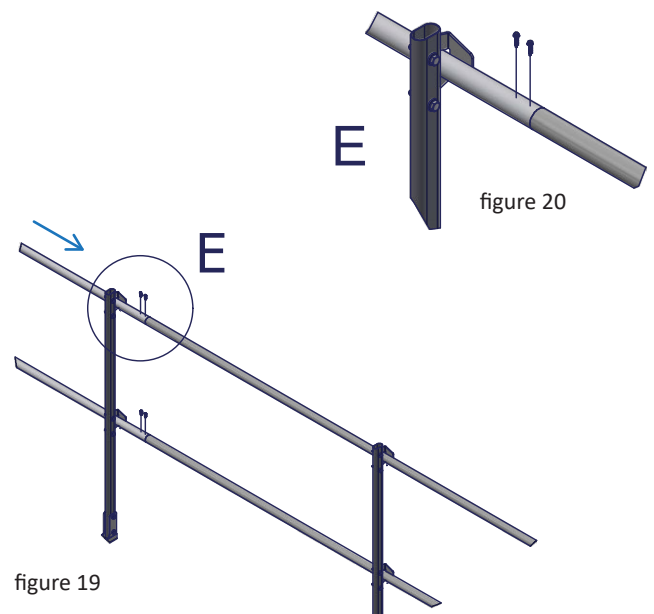

figure 19

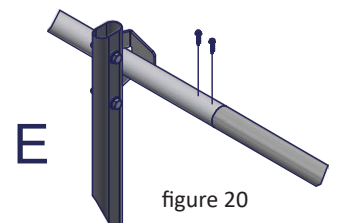

figure 20

Place the diagonal support brackets between the lower handrail and the outer posts as shown in figure 22.

Lock the diagonal support brackets with four 4,8 x 19 mm drill vap screws per bracket. The same diagonal support fits both ends of the railing. The position of the diagonal support differs by 180° between the start and end ends.

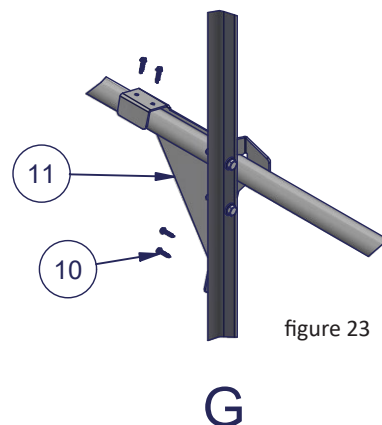
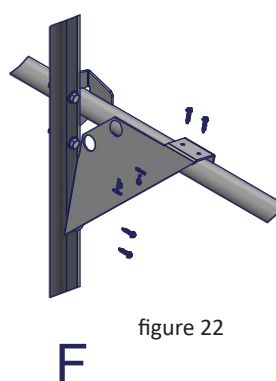
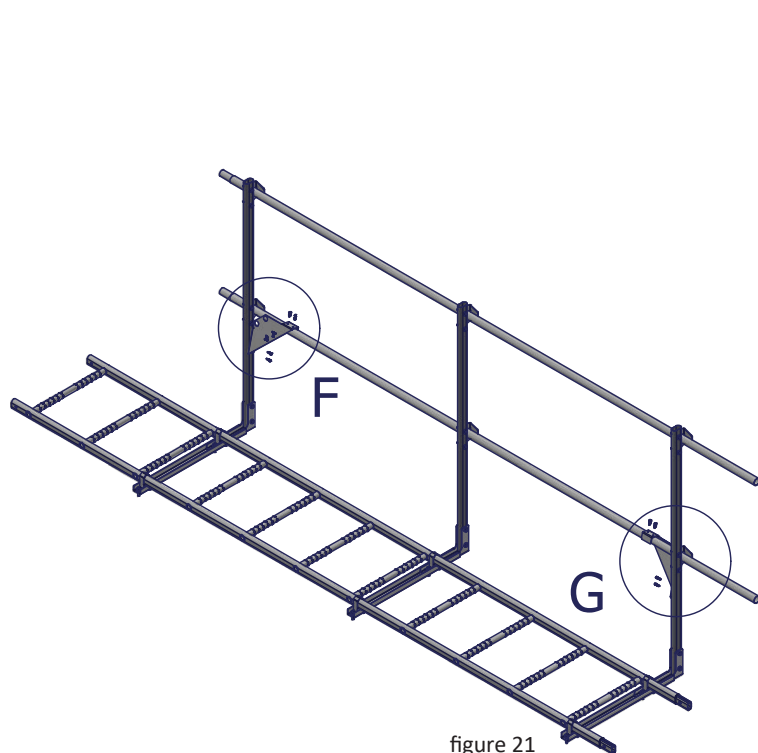

figure 21

figure 22

figure 23

Finish the installation by placing plastic seals on the ends of the posts. Tap the seals lightly into place, e.g., with a hammer.

Part	Description
10	Drill vap screw 4,8 x 19 mm (594)
11	Safeguard diagonal support bracket (777)
12	Plastic seal (584)

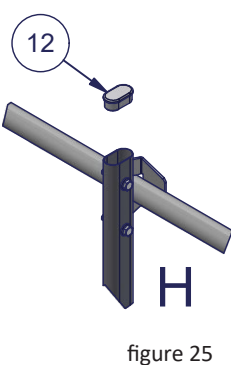
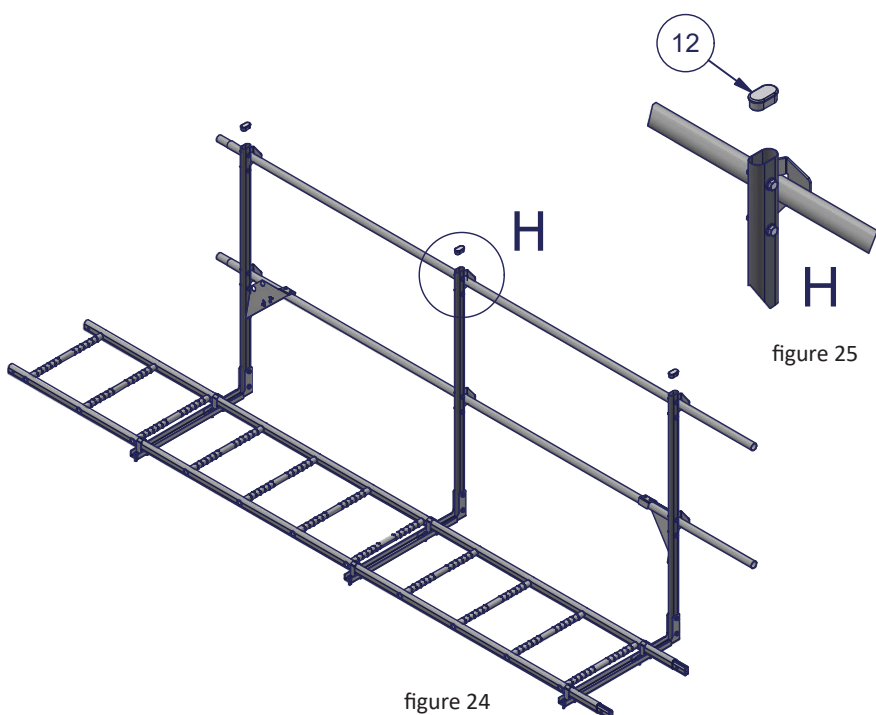
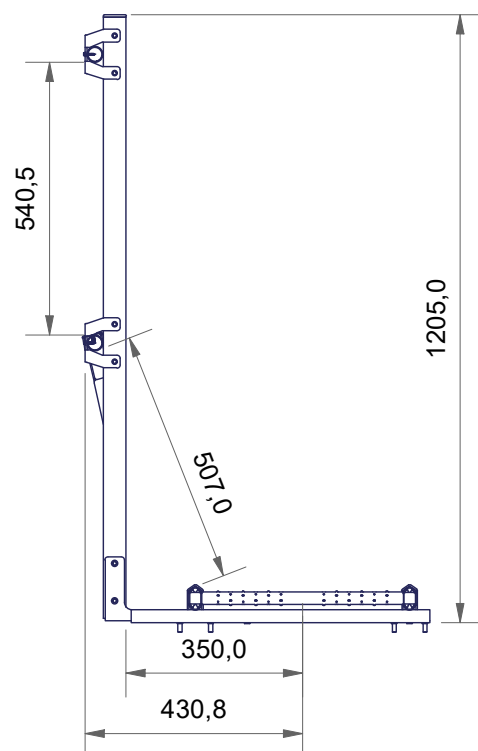

figure 24

figure 25

Main dimensions



INSTALLATION OF ENDSTOP

Take two end-stop clips. Install the endstop on the inside of the last railing post, not at the end of the handrail.

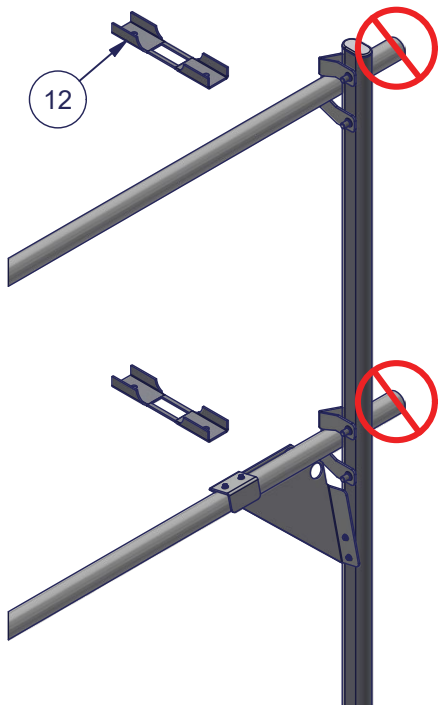

figure 1

Bend the clips around the upper and lower handrail.

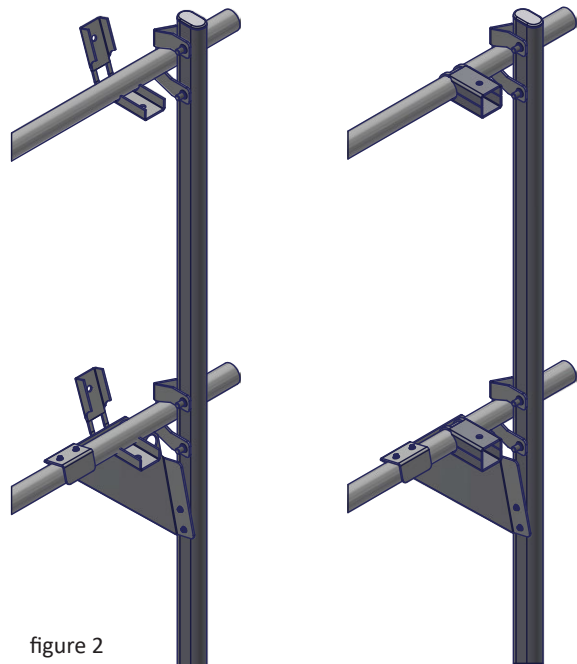

figure 2

Part	Description
12	End-stop clip (624)
13	Endstop (778)
14	Bolt 8 x 60 mm (598)
15	M8 flange nut (729)

Place the endstop inside the clips.

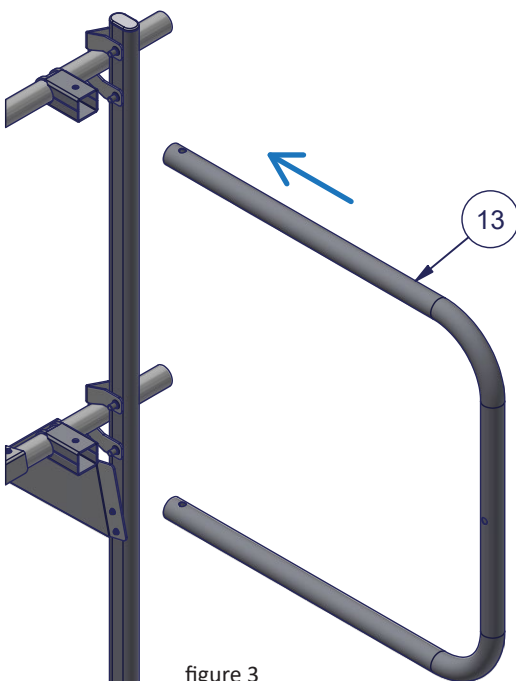

figure 3

Insert two M8x60 bolts through the holes in the clips and the endstop. Tighten the bolts and nuts to a torque of 12 Nm.

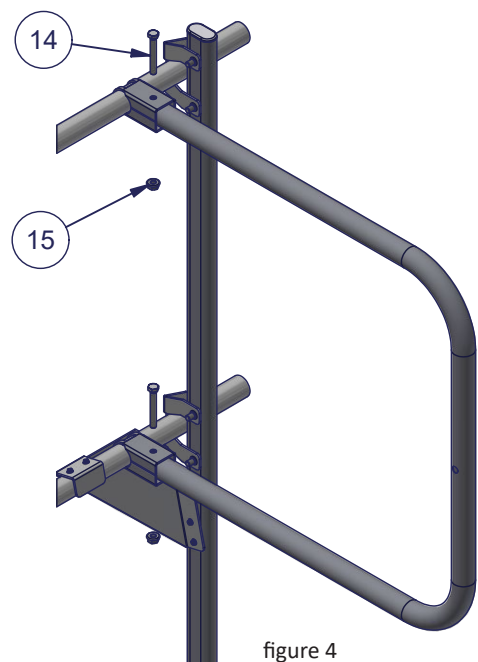

figure 4

Place the diagonal support bracket on top of the upper handrail and endstop as shown in the figure 6. Secure the diagonal support bracket with four 4,8 x 19 mm drill vap screws.

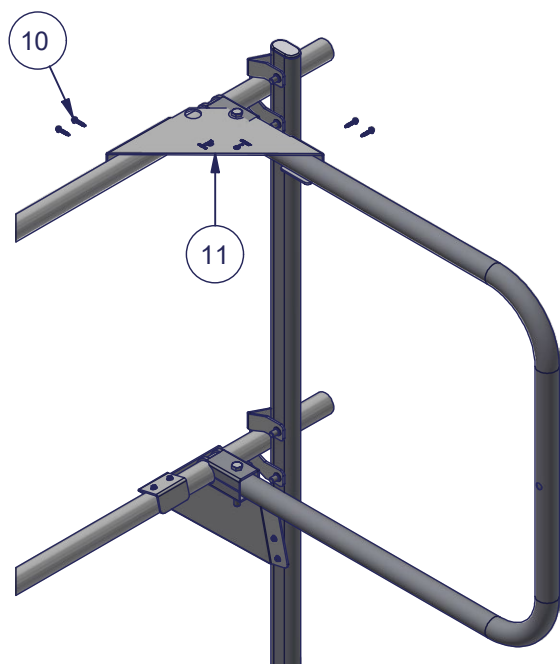

figure 5

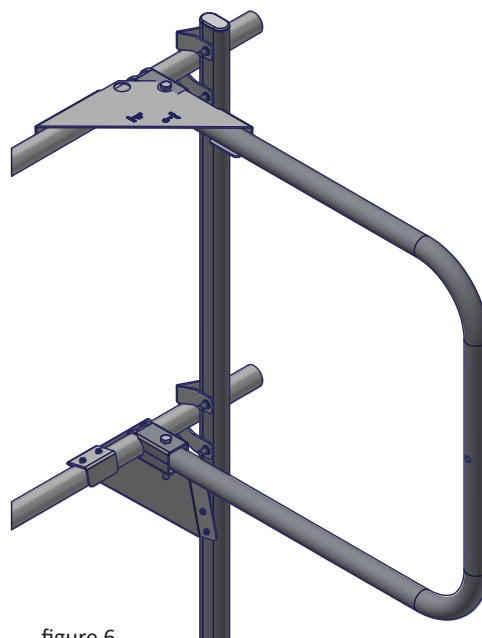

figure 6

Part	Description
10	Drill vap screw 4,8 x 19 mm (594)
11	Safeguard diagonal support bracket (777)

INSTALLATION OF CORNER ROD

Leave the handrails in the corner long or do not lock them with drill vap screws at this stage.

The maximum distance between the posts is 1200 mm when the horizontal handrails are extended with corner rods.

Bend the corner rod to suitable angle.



figure 1

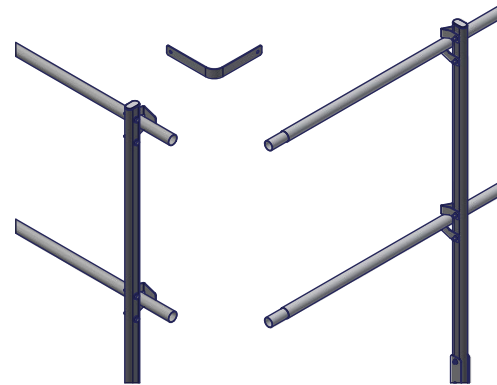

figure 2

Part	Description
10	Drill vap screw 4,8 x 19 mm (594)
16	M8 flange nut (729)
17	Safeguard corner rod (776)
18	Safeguard corner rod fixing bracket (775)
19	M8x16 Flange screw (731)

Attach the corner rod fixing brackets to both ends of the corner rod with M8X16 flange screws and M8 flange nuts. Do not tighten the connections completely at this stage.

Fit the corner rod into place. Cut the handrails to appropriate length and lock them in place with drill vap screws.

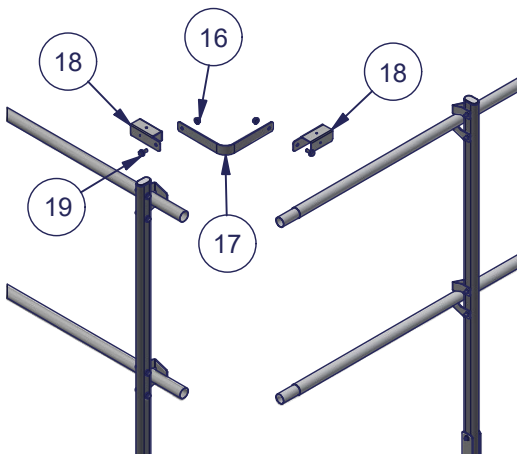

figure 3

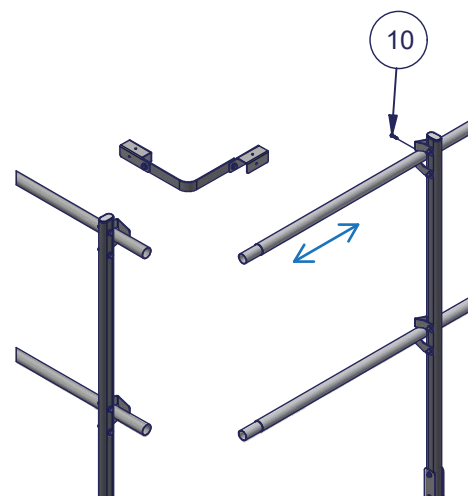

figure 4

Attach the corner rod brackets to the handrails with two drill vap screws at both ends (figure 5). Tighten the bolts and nuts of the corner rod brackets to a torque of 12 Nm.

Repeat steps 1-5 for the second handrail.

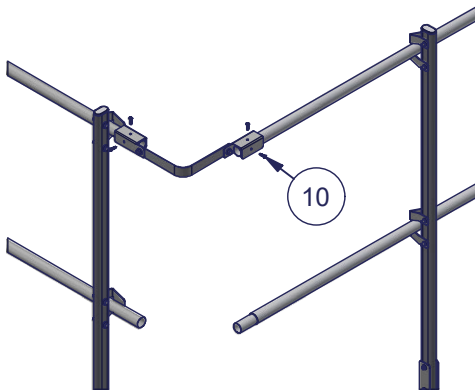

figure 5

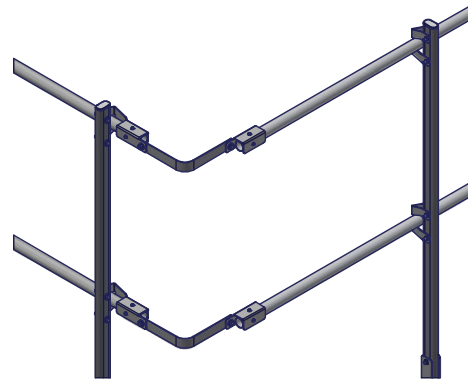

figure 6

Corner joints can also be made in the same way in situations where the railing continues from a roof walkway to a roof ladder, for example (figure 7).

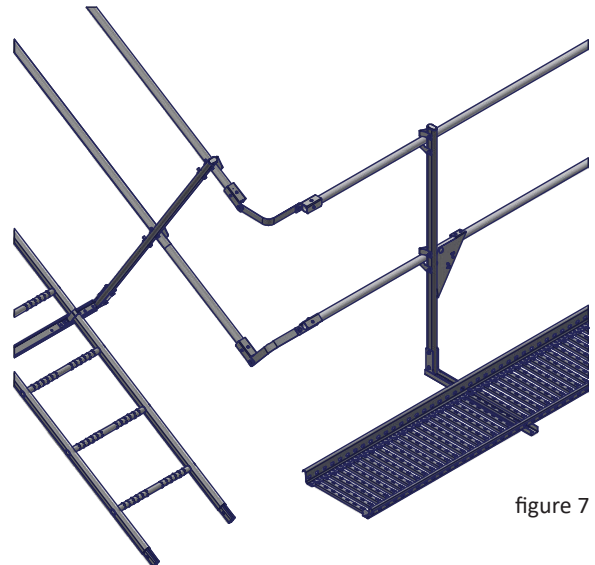

figure 7

Corner joints can also be made for very slight changes in pitch, for example over the ridges of flat roofs (figure 8).

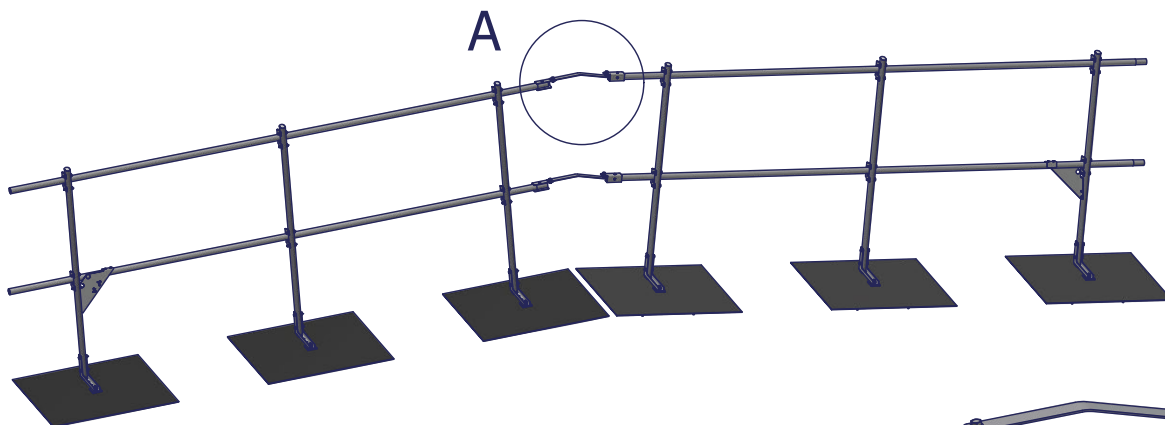

figure 8



figure 9

INSTALLATION OF A THIRD HANDRAIL

Safeguard railing can be equipped with a third handrail. This reduces the gap between the walkway and the lower horizontal rail.

Install the handrail brackets with same M8x40 flange screws that are used to attach the posts to the post brackets.

Slip the handrail through the brackets.

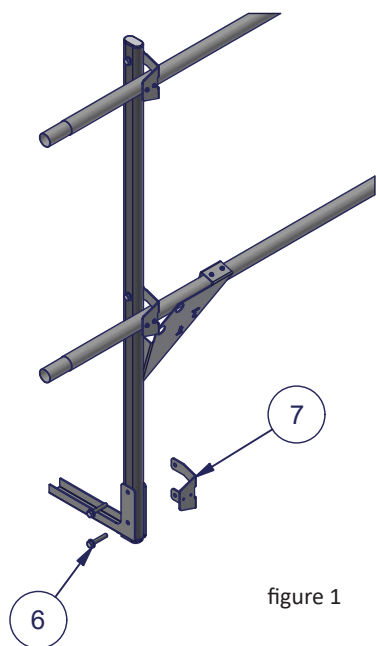

figure 1



figure 2

Part	Description
6	M8x40 Flange screw (733)
7	Safeguard handrail bracket (771)
9	Handrail (Pisko snow guard pipe 502)
10	Drill vap screw 4,8 x 19 mm (594)

Lock the bottom handrail at the first and last handrail brackets with two drill vap screws. Lock the handrail extensions in the same way as the other handrail extensions.

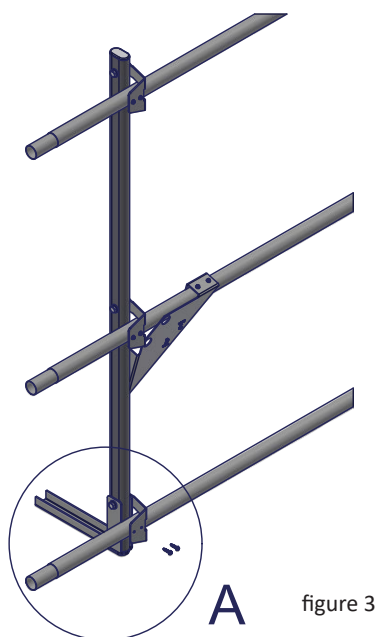

figure 3

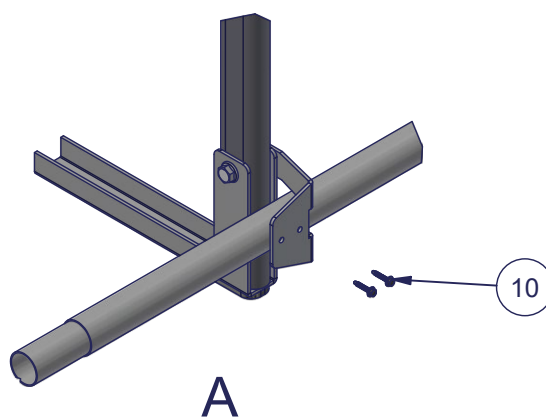

figure 4

USE

- Ensure the official commissioning inspection has been completed by the installer.
- Instructions for using the access ways can be found in the separate product-specific instructions for the access ways. Please read them before using the system.
- Pisko Safeguard acts as an attachment point for a safety rope. If the user must leave the railing and enter a hazardous area, the post bracket is the recommended place to attach the safety rope. Do not attach the safety rope to handrails or diagonal supports! Attached users must be at least 3 meters apart.
- The user must ensure that appropriate and compliant personal protective equipment (such as a harness) is used. Harnesses must be used in accordance with the manufacturer's instructions.
- Use only proper safety ropes intended to be used as a Personal Protective Equipment. The maximum user weight is determined by the value indicated on the safety rope.
- Pisko Safeguard is a system designed to prevent entry into hazardous areas. It is not intended for use as a load carrier.
- The system must not be used if it is found to be damaged.
- The access way on which Pisko Safeguard can be installed must be a Class 2 access way intended for use as a safety rope attachment point in order for the Pisko Safeguard system to be used as a safety rope attachment point.
- The Pisko Safeguard guardrail system is not intended for use in construction, sports, or recreational activities.

MAINTENANCE

To ensure the reliability and safety of the Safeguard system, the property owner must carry out yearly inspection and maintenance procedures, by a professional authorized by the manufacturer. Yearly Maintenance inspection checklist for Pisko Safeguard guardrail system:

- Ensure that the information and documentation of the company that carried out the installation can be found on site. Review the original commissioning report.
- Check the tightness of joints, connections and attachments.
- Check the condition of all system components for damage.
- If the system is attached to a roof walkway or roof ladder, the condition of the walkways is also inspected in accordance with the product-specific inspection program.
- Damaged parts must be replaced immediately.
- Damaged parts may only be replaced with original parts or parts supplied by Piristeel Oy that are equivalent to the original parts.
- Further information on inspections can be found in a separate inspection report.