

Pisko roof walkway to low slope steel roofs with Pisko MultiFast Optim (Roof pitch 0° - 14°)

INSTALLATION

Place EPDM sealant strip (2) or alternatively Pisko 2+1 sealants (2) (4 / fastener) to the bottom of the MultiFast Optim bracket (1).

Attach the MultiFast Optim bracket (1) to the top of the profile with 12 Pisko sheet metal screws of stainless steel (3). Fasten the screws according to the pattern shown in the drawing. **Do not overtighten!**

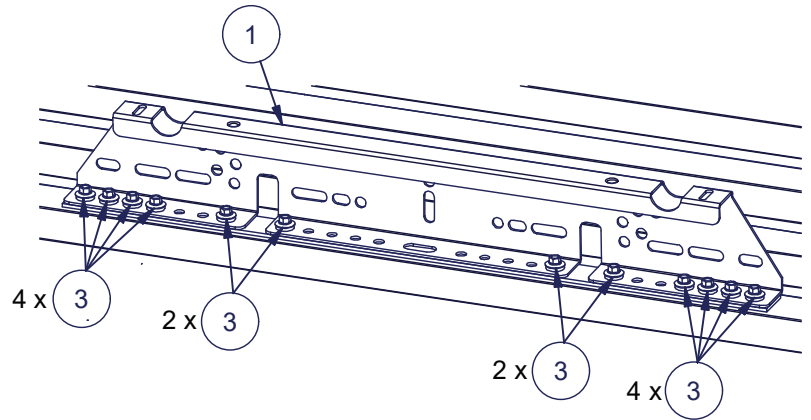
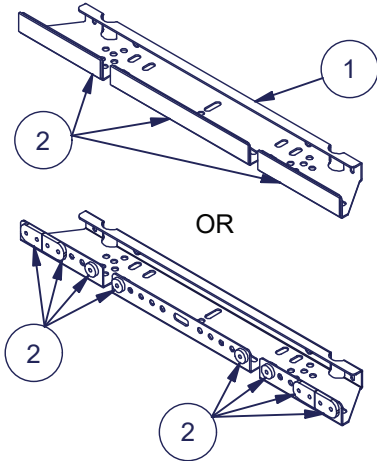

Fasten the adjustment plate for walkway (4) to the MultiFast bracket (1) on the eaves side with 2 M8x16 bolts (5) and M8 nuts (6) and adjust correct angle.

The mounting angles and corresponding mounting holes. The mounting holes are symmetrical at both ends of the MultiFast and the adjustment plate.

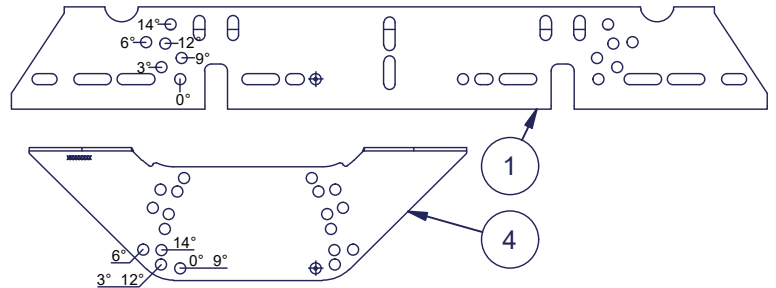
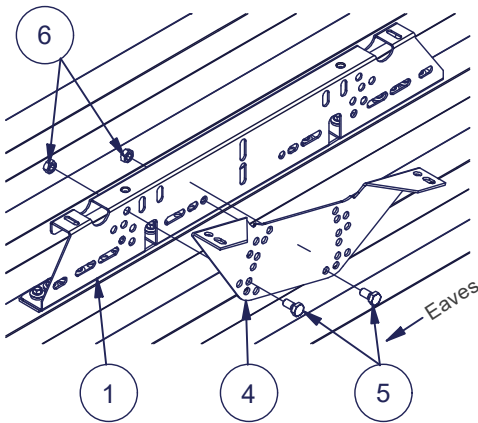

Attach the walkway (7) to MultiFast brackets (1) with 2 flange bolts (8) and flange nuts (9).

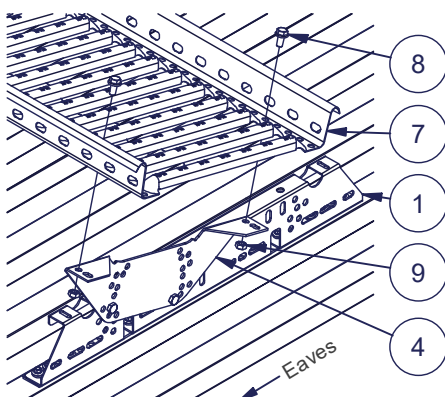

Part	Description
1	MultiFast Optim
2	Adhesive sealant / Pisko 2+1 sealant
3	Pisko sheet metal screw 6,3x19 A2
4	Adjustment plate for walkway
5	Bolt DIN 933 - M8 x 16 HDG *
6	Nut DIN 934 - M8 HDG *
7	Roof walkway
8	Flange bolt DIN 6921 - M8 x 16 HDG *
9	Flange nut DIN 6923 - M8 HDG *

* HDG or equal corrosion protection

The Roof walkway must always be installed with at least 3 MultiFast brackets.

- The max. distance between brackets is 1100 mm.
- The max. overhanging of the walkway from outermost brackets is 200 mm.

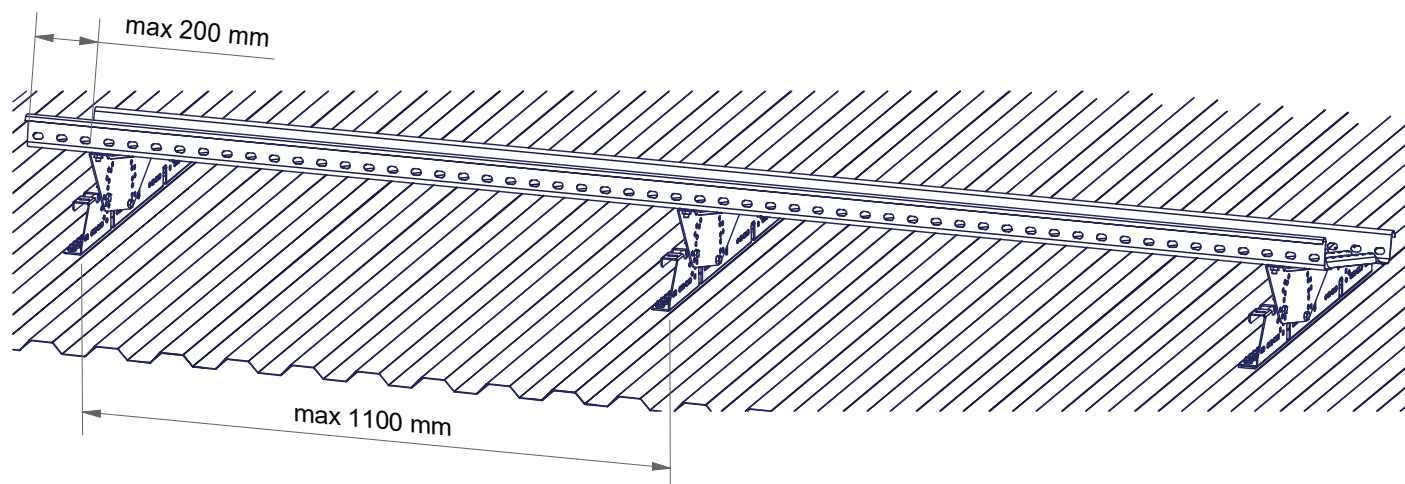

The extension of the walkway (7) shall be done by overlapping (min 2 crossbars) and securing the connection from both sides with two M8x16 flange bolts (8) and M8 flange nuts (9).

Requirements for min. raw material thickness:

- Steel plates - 0,5 mm

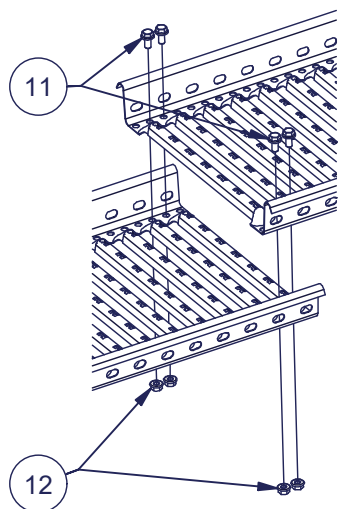

USE

A roof walkway must be used when the roof inclination is more than 1:8. If the height of the building is more than 9 meters, safety rope fixing structures must be provided (Finnish Ministry of the Environment, Decree on the safe use of buildings on January 1, 2018). The EN 516 standard gives two performance classes for roof walkways: class 1 and class 2. Class 1 means that the product is suitable for use as access way and class 2 means that the product can also be used as a safety rope anchoring point. Personal fall arresters may only be attached to class 2 roof walkways. Pisko roof walkway has been dimensioned against 1,5 kN (~150 kg) concentrated load (load from the user).

The Pisko roof walkway to low slope steel roofs with Pisko MultiFast Optim fastener is manufactured in compliance with EN 516 and it has passed the static and dynamic tests specified in the relevant standard for class 2. An appropriate safety rope can be fixed to a roof walkway, which is installed in accordance with class 2. The safety rope must be intended to be used as a personal safety rope and it must conform to relevant standards such as e.g. EN 353-2 and should be equipped with a shock absorber (EN 355). A Pisko SafeLine wire system's glider, a horizontal carriage that moves along the Pisko safety rail or, alternatively, a rope fastener is used as a safety rope attachment point with Pisko roof walkways (see the separate installation instructions for these products). Moreover, the following must be taken into consideration when using a safety rope:

- Only safety ropes (e.g. EN 353-2) or retractable lanyards (EN 360) that are meant to be used as a personal fall protection equipment should be used.
- Only one person at a time, with a total weight of max. 150 kg, including the equipment, is allowed to fix a safety rope to a safety rope anchoring point.
- The distance between attachment points must be at least four (4) meters if more than one user is attached to the same roof walkway or horizontal safety rail.
- More than one person can be attached simultaneously to the Pisko SafeLine that is installed on a roof walkway, provided that there is at least two wire holder brackets in between the users. More information on Pisko SafeLine installation instructions.
- The safety rope may only be used towards the eave on the pitched roof area where the roof walkway is installed.

MAINTENANCE

Pisko products are hard-wearing and safe to use, guaranteed by the ongoing quality control and development work by Piristeel Ltd, as well as correct installation of the products according to the manufacturer's instructions. To ensure the reliability and safety of the products, the property owner must carry out yearly inspection and maintenance procedures, and monitor that the snow load specified by the regulations is not exceeded.

The property owner must have all roof safety products, that have been installed and used according to class 2, and personal safety equipment inspected by a professional authorized by the manufacturer.

Yearly maintenance inspection checklist for Pisko products:

- Check the tightness of joints, connections and attachments.
- Check the roof attachments (fixings).
- Ensure any excessive snow load is cleared to minimize the strain on structures and attachment points (as necessary; there might be a need several times during the winter).
- As necessary, clear the roof walkways of snow and ice.
- Check the paintwork and zinc coating of the products; repair faults and touch up paintwork if necessary.
- Replace or repair any damaged or faulty parts as soon as possible.

Piristeel Oy Metallitie 4, 62200 Kauhava Finland 24
EN 516 Pisko roof walkway for low inclination steel roofs with Pisko MultiFast Optim bracket 1395 Type B Mechanical strength: Class 1 and Class 2 Reaction to fire: Class A1 Durability: Z275 + powder coating 80 µm External fire performance: DTS

This product has been installed in accordance with the installation instructions by

Company

Installer

Date