

PISKO SAFEGRIP ROOF LADDER FOR WATERPROOFING MEMBRANE ROOF WITH MOUNTING PLATE FOR WATERPROOFING MEMBRANE ROOF

Pisko roof ladders for waterproofing membrane roof are used as extensions of wall-mounted ladders and/or roof walkways to create safe access routes on waterproofing memberane roofs. It must be possible to move safely on the roof from eaves to the ridge, chimneys, sunroofs and other areas requiring maintenance Pisko ladders have a rung width of 400 mm and rung diameter of 25 mm.

INSTALLATION

Roof ladders must be attached to the load-bearing structures of the roof, at least at the top and bottom ends of the ladder (EN 12951, Section 5.3.1). Due to the strain created by snow loads, we recommend the use of more fastenings to roof structures.

If the ladder is to be extended, the extension must be attached to the top end of the ladder. Secure the joint with M8x40 hexagon bolt and M8 hexagon nut (figure 2).

The installation of the mounting plate for waterproofing membrane roof should be done according to the instruction for installation, mounting plate for waterproofing membrane roof. Figure 3 shows the installation principle of the fastening solution.

EPDM sealant strip is attached to to bottom of the roof ladder central fastener. Fix the roof ladder center fastener to the mounting plate by using one M10 nut.

Install the roof ladder fasteners (support feet) to the ladder frame at approximately 1400 mm intervals (figure 1). Place the roof ladder rubber seals at the base of the roof ladder fasteners. Attach the roof ladder fasteners to the ladder frame with M8x30 hexagon bolts.

Place the ladder frame on the center fasteners and fold and lock the mounting flanges of the central fastener in their positions by using M8x30 mm hexagon bolts. The central fasteners should be installed in the lower and upper end of the ladder. The longest allowed distance between the central fasteners is 5000 mm. Add more central fasteners, as necessary. The central fastener should be installed at a minimum distance of 100 mm from the side rail (figure 1).

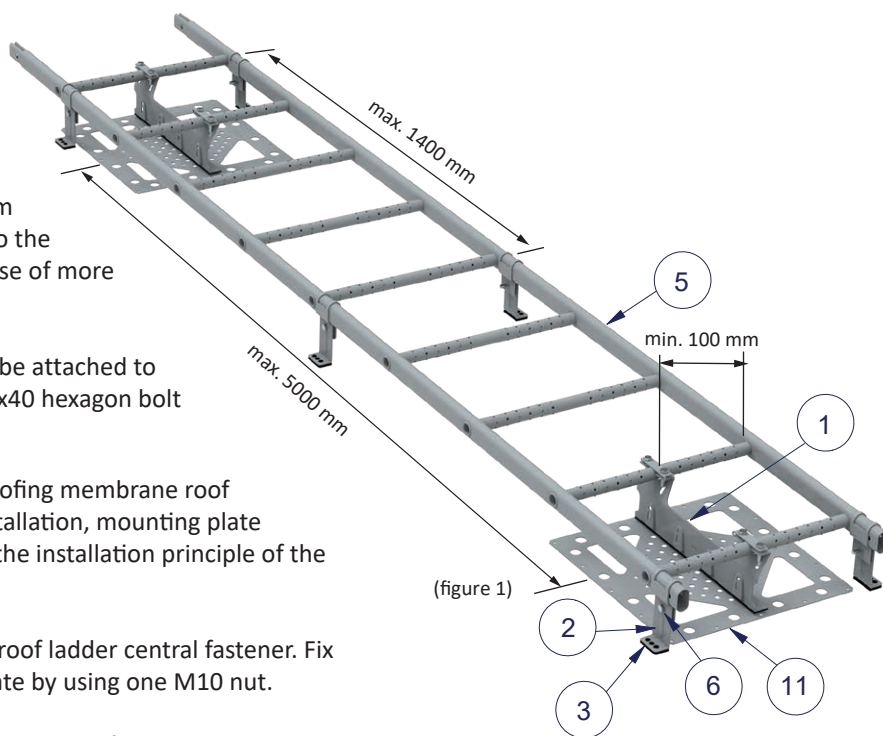

(figure 1)

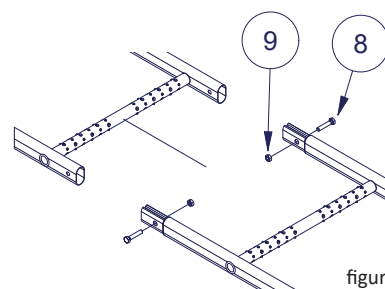
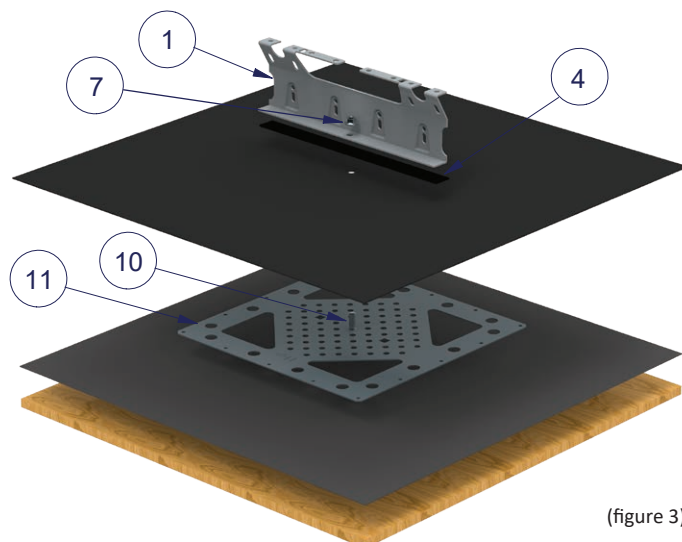

figure 2

Part	Description
1	Roof ladder central fastener
2	Roof ladder fastener, low (total height 134 mm)
3	Roof ladder rubber seal
4	EPDM sealant strip
5	Pisko SafeGrip ladder
6	Hexagon bolt M8x30, hot-dip galvanized
7	M10 Nut DIN6923, A2
8	Hexagon bolt M8x40, hot-dip galvanized
9	Hexagon nut M8, hot-dip galvanized
10	Mounting plate bolt 10x30mm, A2
11	Mounting plate for waterproofing membrane roof



(figure 3)

ADDITIONAL BRACKET FOR UNISEAM CENTRAL FASTENER

Roof ladder can also be installed on the Mounting plate for waterproofing membrane roof with Roof ladder central fastener, Pisko Uniseam, when combined with UniSeam additional bracket set, M10 as shown in figure 4. Using the M8 flange bolts and nuts supplied with the additional bracket set, attach the additional bracket against the flat surface of the UniSeam central fastener. Install a 2+1 seal at the bottom of the additional bracket, divided at both ends and the anchor point sealant in the middle.

Part	Description
1	Roof ladder central fastener, Pisko Uniseam
2	UniSeam additional bracket set, M10
3	Pisko 2+1 seal
4	M8x16 Flange screw ZnNi, non serrated
5	M8 Flange nut ZnNi, non serrated
6	Anchor point sealant EPDM

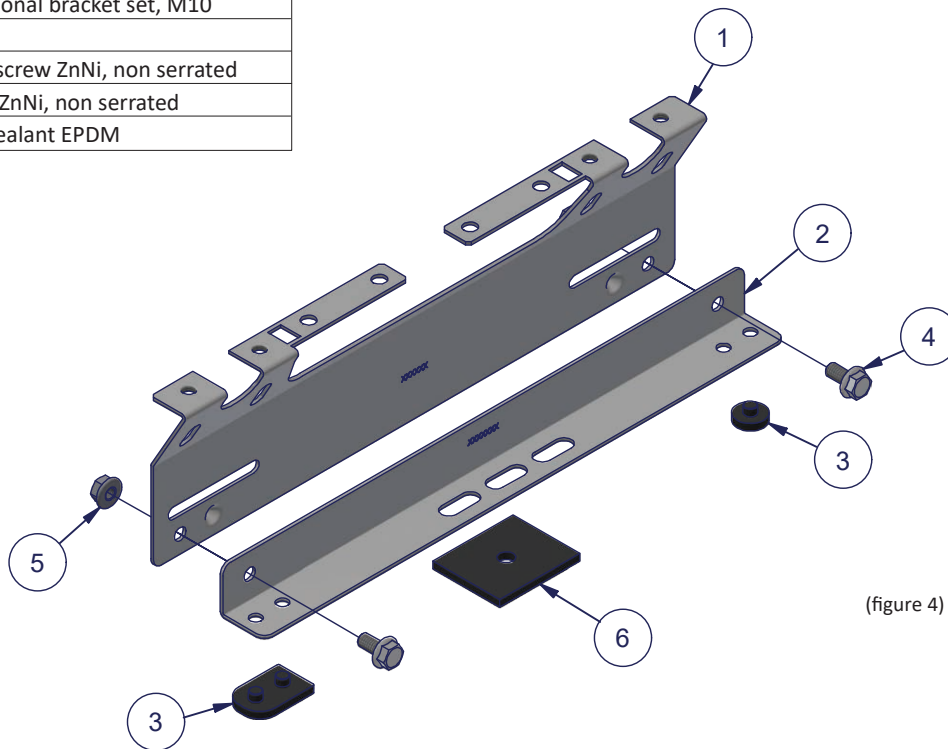

(figure 4)

USE

Roof ladder must be used when the roof inclination is more than 1:8 and they are also recommended for roofs with lower slopes than this. If the height of the building is more than 9 meters, safety rope fixing structures must be provided (Ministry of the Environment Decree on the safe use of buildings on January 1, 2018). Standard EN 12951 provides two performance classes for roof ladders: class 1 and class 2. Class 1 means that the product is suitable for use as access way and class 2 means that the product can also be used as safety rope anchoring point. Using personal fall protection equipment, a person is only allowed to attach themselves to a roof ladder with class 2 performance level. Pisko SafeGrip roof ladder has been dimensioned against 1,5 kN (~150 kg) concentrated load, i.e. working load, required by the standard.

The Pisko SafeGrip roof ladder conforms to standard EN 12951, having undergone static and dynamic tests per class 2. An appropriate safety rope can be fixed to a roof ladder, which is installed in accordance with class 2. The safety rope must be intended to be used as a personal safety rope and it must conform to relevant standards e.g. EN 353-2 and should be equipped with a shock absorber (EN 355). On Pisko SafeGrip ladders, the safety rope anchoring point is the Pisko SafeLine wire system's glider (see separate installation instructions) or the ladder frame. When using the safety rope, the following points must be taken into account:

- The ladder has undergone periodic inspections and is suitable for use as safety rope anchoring point
- Only safety ropes (e.g. EN 353-2) or retractable lanyards (EN 360) that are meant to be used as a personal fall protection equipment should be used
- The Pisko SafeLine installed on the roof ladder may only be used by one person at a time, for more information see the Pisko SafeLine instructions for installation, use and maintenance
- If the ladder is not equipped with the Pisko SafeLine system, the recommended safety rope fixing point is the side stile of the ladder
- Only one person at a time, with a total weight of max. 100 kg, including the equipment, is allowed to fix a safety rope to the roof ladder.
- The safety rope must be fixed to the roof ladder only in the space between the roof ladder fasteners that connect the ladder to the roof structure.
- The safety rope shall never be fixed to the support feet of the ladder
- The safety rope may only be used towards the eave on the pitched roof area where the roof ladder is installed

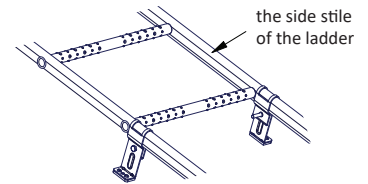

MAINTENANCE

As long as the Pisko products are installed in accordance with the instructions, they have a long life cycle and they are safe to use, guaranteed by the continuous quality control and R&D by Piristeel Oy. In order to ensure the safe use and the long life cycle, the property owner must perform the annual inspection and maintenance procedures and ensure that the snow load is not exceeded, as specified in the regulations.

To ensure the durability of the performance of the products, the property owner should have the class 2 roof safety products inspected annually by a person authorised by the manufacturer.

The annual inspection and maintenance areas for the Pisko roof ladders:

- Check the tightness of the joints and points of attachment.
- Check the fastenings in the roof.
- Remove the excessive snow load in order to minimize the stress on structures and points of attachment (as necessary, several times during winter).
- As necessary, remove snow and ice from the ladder.
- Check the painted and galvanized product surfaces and, as necessary, repair local damages and perform touch-up painting.
- Replace or repair any damaged or faulty parts as soon as possible.

Piristeel Oy Metallitie 4, 62200 Kauhava Finland 18
EN 12951 Pisko SafeGrip roof ladder with mounting plate for bitumen roof, 1347 TB Mechanical strength: Class 1 and Class 2 Fire safety: Class A1 Durability: Z275 + powder coating 80µm (External parts of the roof) Resistance to external fire: Estimated to meet the requirement

This product has been installed in accordance with the installation instructions by

Company

Installer

Date

--	--	--