

PISKO SAFEGRIP ROOF LADDER FOR STANDING SEAM ROOF

Pisko roof ladders for a standing seam roofs are used as extensions of wall-mounted ladders and/or roof walkways to create safe access paths on a standing seam roofs. It must be possible to move safely on the roof from the eaves to the ridge, chimney, sunroofs and other areas requiring maintenance. Pisko ladders have a rungwidth of 400 mm and rung diameter of 25 mm.

INSTALLATION

Roof ladders must be attached to the load-bearing structures of the roof, at least at the top and bottom ends of the ladder (EN 12951, Section 5.3.1). Due to the strain created by snow loads, we recommend the use of more fastenings.

If the ladder is to be extended, the extension must be attached to the top end of the ladder. Secure the joint with M8x40 hexagon bolt and M8 hexagon nut (figure 6).

You will need the following for the installation: roof ladder central fasteners for the ladder's top and bottom ends, roof ladder fasteners and striking plate for standing seam roof for central fasteners.

- Place the roof ladder rubber seals at the base of the roof ladder fasteners (figure 3).
- Attach the roof ladder fastener to the side rail with one M8x30 hexagon bolt (figure 3).
- Install the roof ladder fasteners in their places on the ladder frame, with maximum intervals of 1400 mm.
- Install the roof ladder central fasteners at least on the top and bottom ends of the ladder. Fold the mounting flanges of the central fastener in their positions.
- The maximum distance between central fasteners is 5000 mm (figure 1).
- Attach the central fastener to the rungs with four M8x30 hexagon bolts (figure 3).
- Lift the assembled roof ladder onto the roof.
- Install the central fastener covers against an intact seam.
- Leave one rung free at the bottom. The roof ladder central fastener should be installed at a minimum distance of 100 mm from the side rail (figure 1).
- Attach the roof ladder to the seam via central fasteners using striking plate for a standing seam roof. Tighten striking plates to the seam with four M8x30 hexagon bolts and M8 hexagon nuts. Tightening torque of the screws is 35 Nm

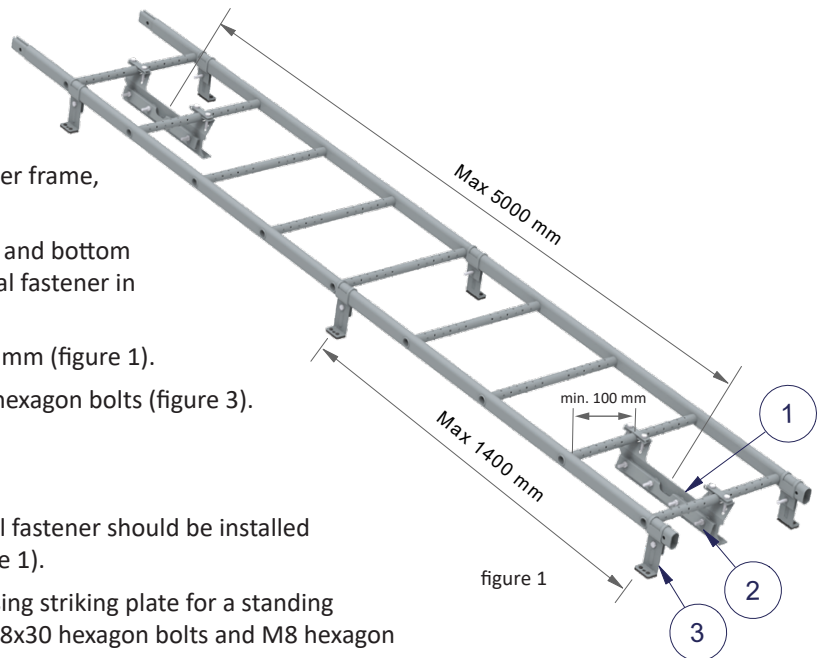

figure 1

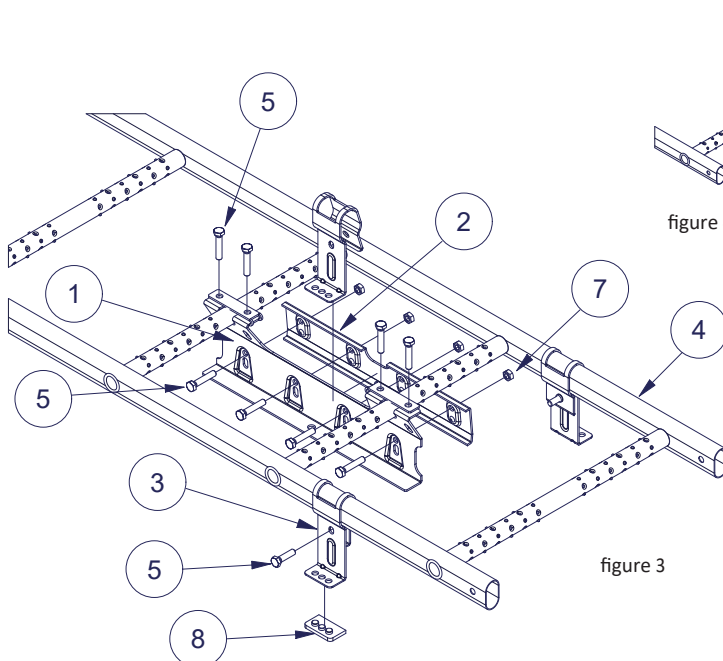

figure 3

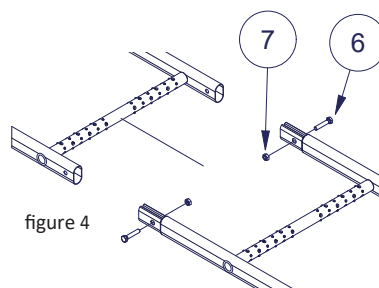

figure 4

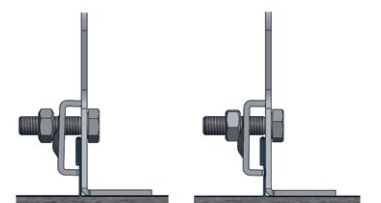

figure 2

Part	Description
1	Roof ladder central fastener
2	Striking plate standing seam roof
3	Roof ladder fastener, low (total height 134mm)
4	Pisko SafeGrip ladder
5	Hexagon bolt M8x30, hot-dip galvanized
6	Hexagon bolt M8x40, hot-dip galvanized
7	Hexagon nut M8, hot-dip galvanized
8	Roof ladder rubber seal

USE

Roof ladder must be used when the roof inclination is more than 1:8 and they are also recommended for roofs with lower slopes than this. If the height of the building is more than 9 meters, safety rope fixing structures must be provided (Ministry of the Environment Decree on the safe use of buildings on January 1, 2018). Standard EN 12951 provides two performance classes for roof ladders: class 1 and class 2. Class 1 means that the product is suitable for use as access way and class 2 means that the product can also be used as safety rope anchoring point. Using personal fall protection equipment, a person is only allowed to attach themselves to a roof ladder with class 2 performance level. Pisko SafeGrip roof ladder has been dimensioned against 1,5 kN (~150 kg) concentrated load, i.e. working load, required by the standard.

The Pisko SafeGrip roof ladder for standing seam roof conforms to standard EN 12951, having undergone static and dynamic tests per class 2. An appropriate safety rope can be fixed to a roof ladder, which is installed in accordance with class 2. The safety rope must be intended to be used as a personal safety rope and it must conform to relevant standards e.g. EN 353-2 and should be equipped with a shock absorber (EN 355). On Pisko SafeGrip ladders, the safety rope anchoring point is the Pisko SafeLine wire system's glider (see separate installation instructions) or the ladder frame. When using the safety rope, the following points must be taken into account:

- The ladder has undergone periodic inspections and is suitable for use as safety rope anchoring point
- Only safety ropes (e.g. EN 353-2) or retractable lanyards (EN 360) that are meant to be used as a personal fall protection equipment should be used
- The Pisko SafeLine installed on the roof ladder may only be used by one person at a time, for more information see the Pisko SafeLine instructions for installation, use and maintenance
- If the ladder is not equipped with the Pisko SafeLine system, the recommended safety rope fixing point is the side stile of the ladder

Only one person at a time, with a total weight of max. 100 kg, including the equipment, is allowed to fix a safety rope to the roof ladder.

The safety rope must be fixed to the roof ladder only in the space between the roof ladder fasteners that connect the ladder to the roof structure.

The safety rope shall never be fixed to the support feet of the ladder

The safety rope may only be used towards the eave on the pitched roof area where the roof ladder is installed

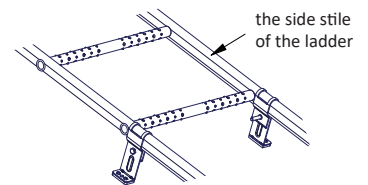

MAINTENANCE

As long as the Pisko products are installed in accordance with the instructions, they have a long life cycle and they are safe to use, guaranteed by the continuous quality control and R&D by Piristeel Oy. In order to ensure the safe use and the long life cycle, the property owner must perform the annual inspection and maintenance procedures and ensure that the snow load is not exceeded, as specified in the regulations.

To ensure the durability of the performance of the products, the property owner should have the class 2 roof safety products inspected annually by a person authorised by the manufacturer.

The annual inspection and maintenance areas for the Pisko products:

Check the tightness of the joints and points of attachment.

Check the fastenings in the roof.

Remove the excessive snow load in order to minimize the stress on structures and points of attachment (as necessary, several times during winter).

As necessary, remove snow and ice from the ladder.

Check the painted and galvanized product surfaces and, as necessary, repair local damages and perform touch-up painting.

Replace or repair any damaged or faulty parts as soon as possible.

CE
Piristeel Oy Metallitie 4, 62200 Kauhava Finland 18
EN 12951 Pisko SafeGrip roof ladder for standing seam roof, 1338 TB Mechanical strength: Class 1 and Class 2 Fire safety: Class A1 Durability: Z275 + powder coating 80 µm Resistance to external fire: Estimated to meet the requirement

This product has been installed in accordance with the installation instructions by

Company

Installer

Date