

Pisko® SafeLine

Installation on standing seam roof with fixing support for SafeLine wire holder bracket

INSTALLATION

Install the mounting platform according to installation instructions: mounting platform for anchor point uniseam (do not attach the anchor point). Maximum distance between SafeLine wire holder brackets is 5 meters.

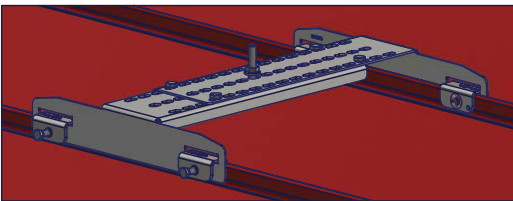

Insert the Fixing support for SafeLine wire holder bracket on the bolt on the mounting platform and fix with M10 flange nut.

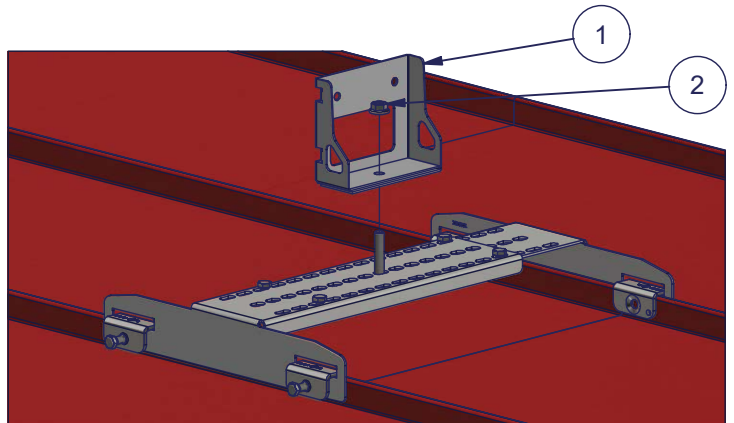

Insert SafeLine wire holder bracket in the fixing support so that the holes are aligned.

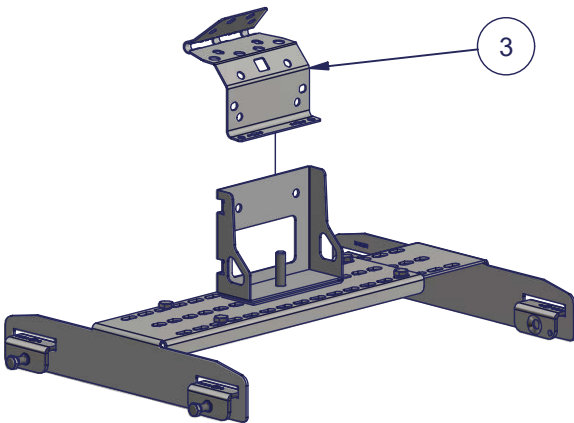

Fasten the wire holder bracket on the fixing support with M8 flange bolts and nuts

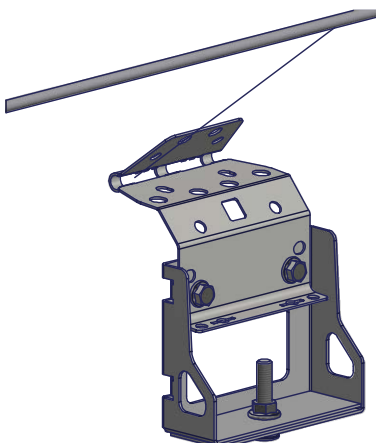
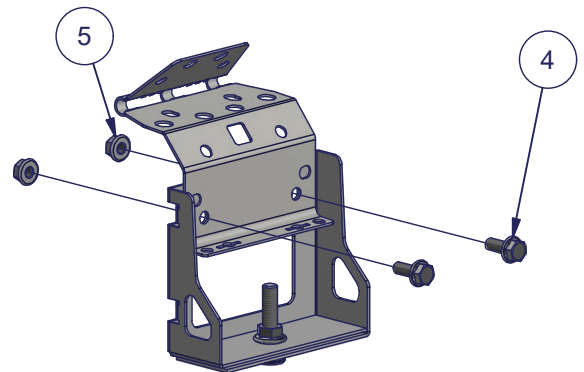

Bend open the top plate of the bracket, so that the wire fits inside the ring shaped elements of the bracket. Insert the wire inside the bracket.

Part	Description
1	Fixing support for SafeLine wire holder bracket
2	M10 flange nut
3	SafeLine wire holder bracket
4	M8 flange bolt, A2 stainless steel
5	M8 flange nut, A4 treated stainless steel

When inserting the wire inside the bracket, make sure the wire is completely inside the ring shaped elements of the bracket. Otherwise the teeth of the bracket might not align correctly with the wire

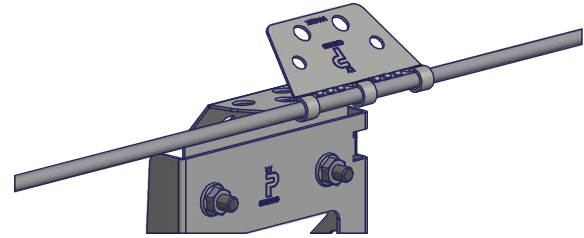
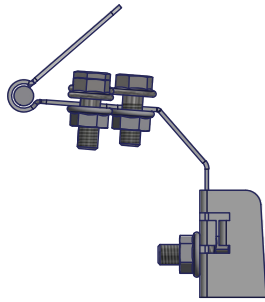

Bend the top plate of the bracket towards the lower plate. While doing this, make sure the wire stays inside the ring shaped elements of the bracket.

Lock the plates together with M8 flange bolts and flange nuts. The tightening torque is approx. 30 Nm, or until the surfaces are completely against each other at the point of attachment.

At the end of the wire, install a glider end stop for wire holder bracket (6) on the last bracket.

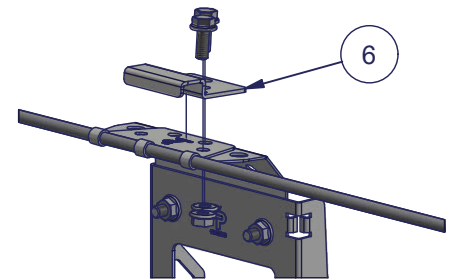
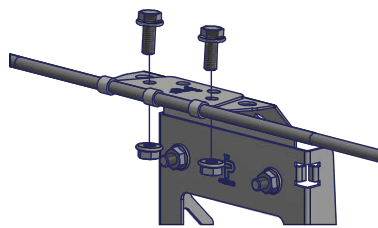
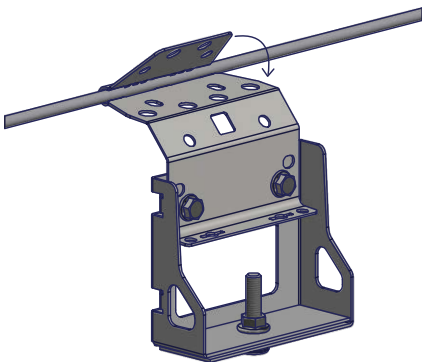

After the last SafeLine wire holder bracket, the end of the wire is turned 180 degrees and is locked against the fixing support with SafeLine wire ending bracket (7). This improves the safety of the user.

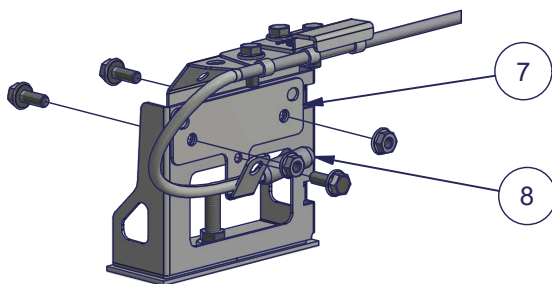

Part	Description
4	M8 Flange bolt, A2 stainless steel
5	M8 flange nut, A4 treated stainless steel
6	Glider end stop for wire holder bracket
7	SafeLine wire ending bracket
8	Wire end protector 8mm, stanless steel

If the loose end of the wire after the last bracket has not been equipped with any factory-mounted terminal, it shall be protected with wire end protector (8) by pressing or using an alternative corresponding method.

A minimum of 40 cm of wire is needed after the last wire holder bracket, so the wire can be safely secured on the side of the fixing support.

When tightening the wire between the brackets, take thermal expansion into account. This is especially important in long, continuous systems without extension terminals. Excess tension should be avoided.

USE

- Ensure the official commissioning inspection has been carried out by the installer
- Use only original parts provided by Piristeel Oy
- Instructions for the proper use of access ways can be found in separate product specific instructions
- Connect to the wire only with a glider certified for Pisko SafeLine system
- Pisko SafeLine wire system is to be used as a fall protection when moving along the appropriate path along the danger zones of the roof. Leaning heavily on the wire while working on the roof might damage the system
- Do not use the system if there is any visible damage
- Access ways used for Pisko SafeLine installation must be executed according to Class 2 performance
- SafeLine installed in a ladder can have only one person at a time
- Two persons are allowed to be attached on the Pisko SafeLine wire simultaneously on a walkway, a bitumen roof installation or a standing seam installation when there are at least two Pisko SafeLine wire holder brackets between the two persons
- Connecting to the wire is only allowed between Pisko SafeLine wire holder brackets. Connecting is NOT allowed after the last bracket, even if there is a loop formed by the wire
- Pisko SafeLine wire system is not suitable for sports or recreational activities
- Make sure that the harness matches the requirements provided in standard EN 361, and that the harness has not been damaged. In addition, adjust the harness to the correct measurements before use of the system, and, if required also adjust the harness during use
- Use only proper safety ropes intended to be used as a Personal Protective Equipment

MAINTENANCE

To ensure the reliability and safety of the products, the property owner must carry out yearly inspection and maintenance procedures, by a professional authorized by the manufacturer.

Yearly Maintenance inspection checklist for Pisko Safeline wire system:

- Check the tightness of joints, connections and attachments
- Check that there are no damaged wire holder brackets, ladder fixing pieces or flat roof fixing pieces for wire holder
- Check that the wire is undamaged
- Check that the glider(s) is undamaged
- Test the movement of glider stoppers for ladders and check that the parts of the stopper are not damaged
- If the wire system is attached to a ladder or a walkway, inspect those parts according to their own maintenance instructions
- Replace any damaged or faulty parts immediately
- Use only original parts provided by Piristeel oy when replacing damaged parts.
- Additional information can be found on separate inspection form or Pisko Pro app



C900083

Commissioning inspection done by

Company

Inspector

Date